

Instruction Manual

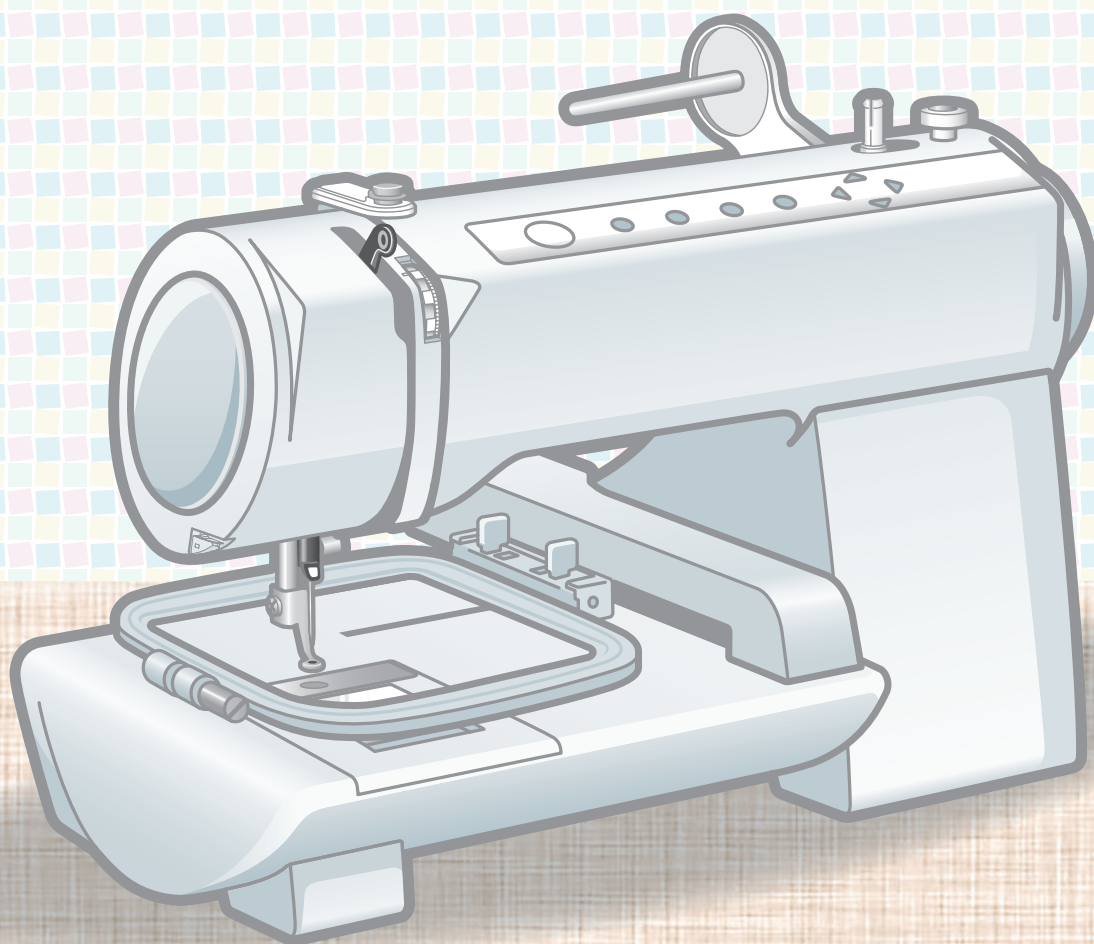

IMPORTANT SAFETY INSTRUCTIONS

When using an electrical appliance, basic safety precautions should always be followed, including the following:

This Embroidery machine is designed and manufactured for household use only.

Read all instructions before using this Embroidery machine.

DANGER — To reduce the risk of electric shock:

1. An appliance should never be left unattended when plugged in. Always unplug this Embroidery machine from the electric outlet immediately after using and before cleaning.

WARNING — To reduce the risk of burns, fire, electric shock, or injury to persons:

1. Do not allow to be used as a toy. Close attention is necessary when this Embroidery machine is used by or near children.
2. Use this appliance only for its intended use as described in this owner's manual. Use only attachments recommended by the manufacturer as contained in the owner's manual.
3. Never operate this Embroidery machine if it has a damaged cord or plug, if it is not working properly, if it has been dropped or damaged, or dropped into water. Return this Embroidery machine to place of purchase with receipt you received at the time of purchase.
4. Never operate the appliance with any air opening blocked. Keep ventilation openings of this Embroidery machine free from accumulation of lint, dust and loose cloth.
5. Never drop or insert any object into any opening.
6. Do not use outdoors.
7. Do not operate where aerosol (spray) products are being used or where oxygen is being administered.
8. To disconnect, turn all controls to the off ("O") position, then remove plug from outlet.
9. Do not unplug by pulling on cord. To unplug, grasp the plug, not the cord.
10. Keep fingers away from all moving parts. Special care is required around the Embroidery machine needle and/or cutting blade.
11. Always use the proper needle plate. The wrong plate can cause the needle to break.
12. Do not use bent needles.
13. Do not pull or push fabric while stitching. It may deflect the needle causing it to break.
14. Switch this Embroidery machine off ("O") when making any adjustment in the needle area, such as threading the needle, changing the needle, threading the bobbin or changing the presser foot, and the like.
15. Always unplug this Embroidery machine from the electrical outlet when leaving it unattended, removing covers, lubricating, making any other adjustments mentioned in this owner's manual or before carrying out maintenance.
16. Before commencing please ensure the hoop movement and machine surrounding area is clear of any object.

SAVE THESE INSTRUCTIONS

For Europe only:

This appliance can be used by children aged from 8 years and above and persons with reduced physical, sensory or mental capabilities or lack of experience and knowledge if they have been given supervision or instruction concerning use of the appliance in a safe way and understand the hazards involved. Children shall not play with the appliance. Cleaning and user maintenance shall not be made by children without supervision.

For outside Europe (except U.S.A and Canada):

This appliance is not intended for use by persons (including children) with reduced physical, sensory or mental capabilities, or lack of experience and knowledge, unless they have been given supervision or instruction concerning use of the appliance by a person responsible for their safety. Children should be supervised to ensure that they do not play with the appliance.



Please note that on disposal, this product must be safely recycled in accordance with relevant National legislation relating to electrical/electronic products. If in doubt please contact your retailer for guidance. (European Union only)

TABLE OF CONTENTS

ESSENTIAL PARTS

Names of Parts	4
Setting the Spool Pin	4
Standard Accessories	5

GETTING READY TO SEW

Connecting the Machine to the Power Supply	6
Presser Foot Lifter	6
Initializing the Embroidery Machine.....	7
Machine Operating Buttons	8
Setting the Spool of Thread	9

Winding the Bobbin

Removing the Bobbin	9
Winding the Bobbin	10
Inserting the Bobbin	11

Threading the Machine

Threading the Machine	12
Handy Threader.....	13
Drawing Up the Bobbin Thread	14
Sliding the needle thread into the thread holder	15
Adjusting the Needle Thread Tension.....	15

Embroidery Hoop

Template.....	17
Setting the Fabric in the Embroidery Hoop.....	18
Attaching the Embroidery Hoop to the Machine.....	19
Removing the Embroidery Hoop from the Machine	20

Connecting the embroidery machine to your device

Access Point Mode Settings	22-23
Client Mode Settings.....	24-25
Sending the Designs to the Embroidery Machine	26

Starting to Sew Embroidery

Basic Sewing	27-28
Resume Function	29
Applique	30
Cutwork	31

CARE AND MAINTENANCE

Replacing Needles	32
Replacing Needles while Embroidering.....	33-34
Thread and Needle Chart	34
Cleaning the Hook Area.....	35-36
Cleaning the Thread Path.....	36

TROUBLESHOOTING

How to Remove Tangled Thread under the Hoop	37
Troubleshooting	38-40
Operation Button Light.....	41

ESSENTIAL PARTS

Names of Parts

- ① Power light
- ② Start/stop button
- ③ Wireless LAN button
- ④ Trace button
- ⑤ Stitch back button
- ⑥ Stitch forward button
- ⑦ Jog buttons
- ⑧ Thread holder
- ⑨ Thread tension dial
- ⑩ Thread take-up lever
- ⑪ Thread guide
- ⑫ Bobbin winder thread guide
- ⑬ Spool pin
- ⑭ Bobbin winder spindle
- ⑮ Bobbin winder stopper
- ⑯ Carriage
- ⑰ Needle clamp screw
- ⑱ Needle bar thread guide
- ⑲ Needle (blue tip needle #75/11)
- ⑳ Needle plate
- ㉑ Hook cover plate
- ㉒ Presser foot
- ㉓ Setscrew
- ㉔ Handwheel
- ㉕ Presser foot lifter
- ㉖ Power switch
- ㉗ Machine socket
- ㉘ Ventilation openings

NOTE:

Embroidery machine design and specifications are subject to change without prior notice.

Setting the Spool Pin

Insert the spool pin into the hole as shown.

- ① Spool pin
- ② Hole

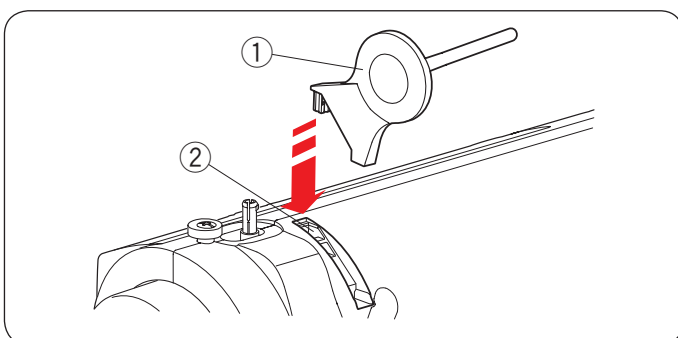
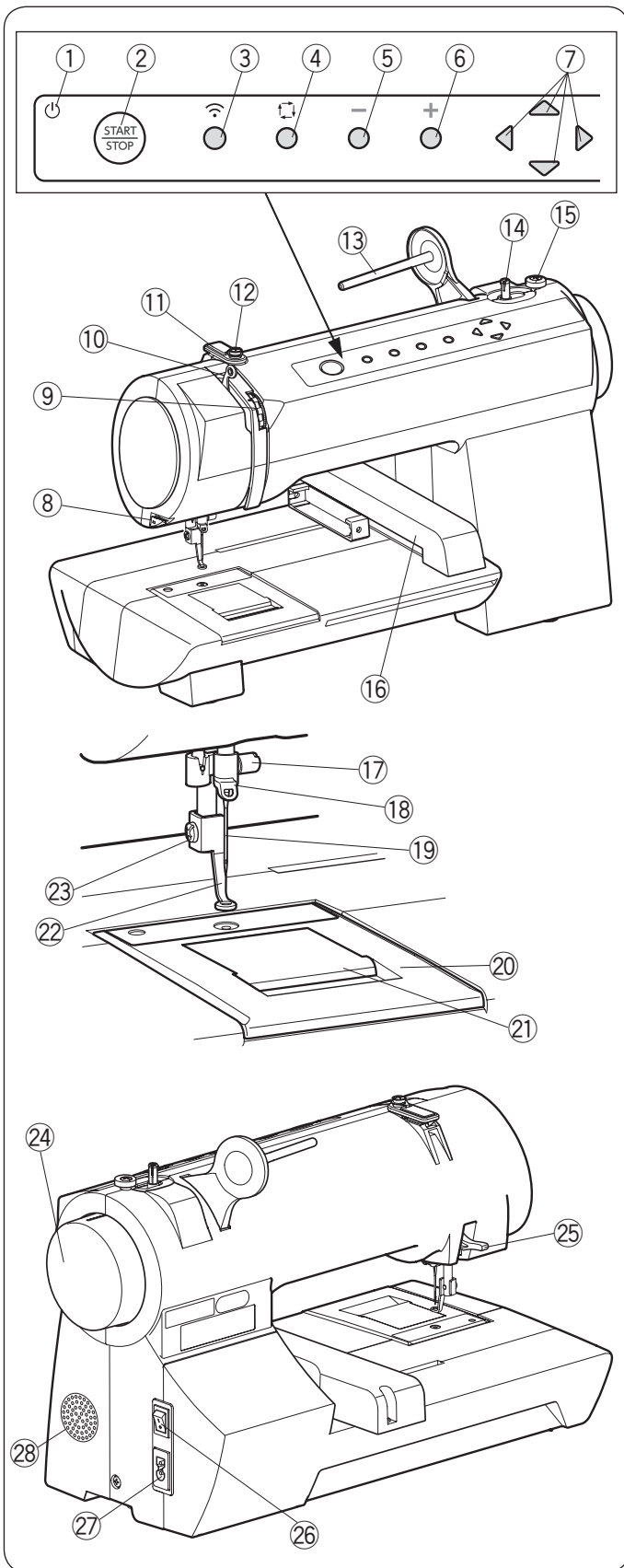

Standard Accessories

No.	Part Name	Part No.
①	Bobbin x 3 (1 set on the machine)	102261000
②	Spool holder (large)	822020503
③	Spool holder (small)	822019509
④	Spool pin	521804002
⑤	Needle x 2 (Size 75/11: Blue tip Needle) (1 set on the machine)	521805003
⑥	Lint brush	802424004
⑦	Screwdriver	653802002
⑧	Handy threader	202024002
⑨	Start-up guide	521803403
⑩	Safety instructions	521807108
⑪	Instruction slip for installing "dot Customizer"	521809100
⑫	Power cable	856519004
⑬	Embroidery hoop SQ10c (with template)	521801010

*The power cable included may differ from the illustration.

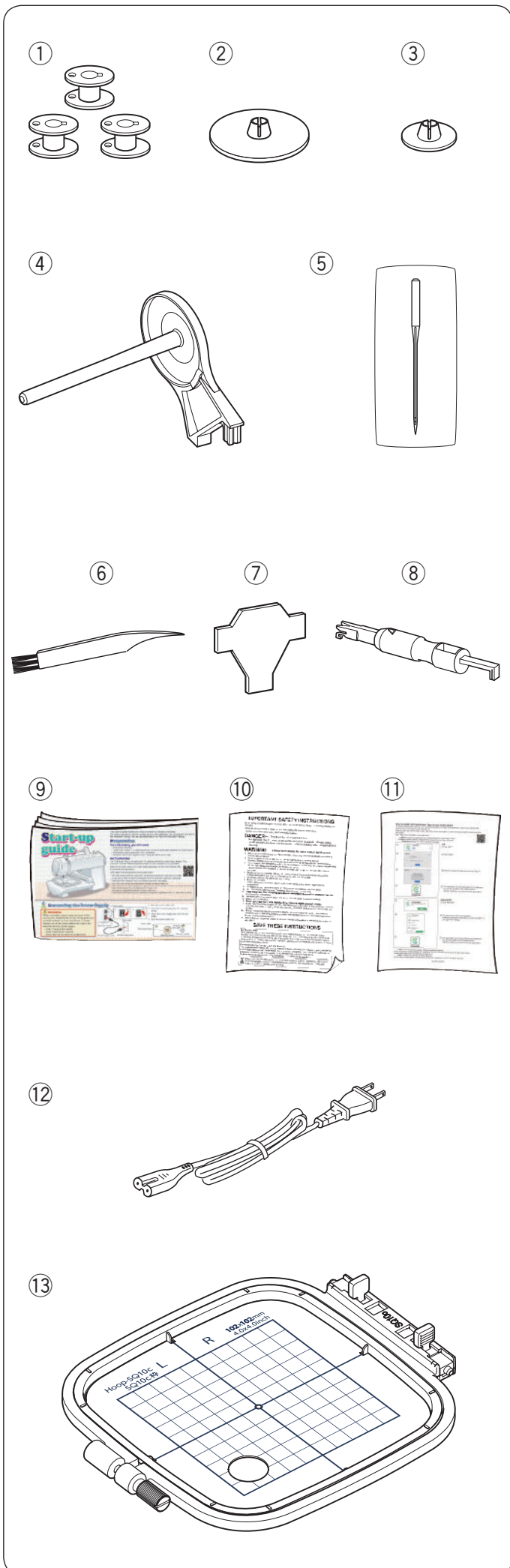

GETTING READY TO SEW

Connecting the Machine to the Power Supply

- 1 Turn the power switch off.
 - ① Power switch
- 2 Insert the machine plug into the machine socket.
 - ② Machine plug
 - ③ Machine socket
- 3 Insert the power supply plug into the wall outlet, and turn the power switch on.
 - ④ Power supply plug
 - ⑤ Wall outlet

NOTE:

Use the power supply cable that came with the machine.

If you turn off the power switch, wait for 5 seconds before turning it on again.

⚠ WARNING:

While in operation, always keep your eyes on the sewing area, and do not touch any moving parts such as the thread take-up lever, carriage, handwheel or needle.

Always turn off the power switch and unplug the machine from the wall outlet:

- when leaving the machine unattended.
- when attaching or removing parts.
- when cleaning the machine.

Presser Foot Lifter

The presser foot lifter raises and lowers the presser foot.

- ① Presser foot lifter
- ② Presser foot
- ③ Lower position

You can raise the presser foot about 5 mm (1/4") higher than the normal up position for easy removal of the presser foot or to set the embroidery hoop.

- ④ Extra lifted position

⚠ WARNING:

Do not turn the handwheel when the presser foot lifter is at the extra lifted position ④.

Do not raise the presser foot lifter to the extra lifted position ④ when the needle is lowered.

Otherwise, it may cause breakage or malfunction.

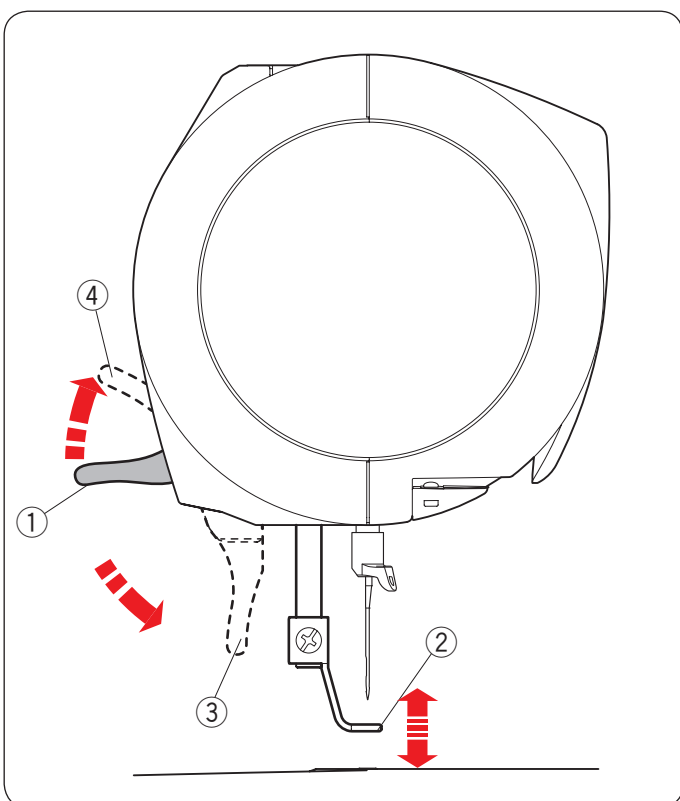
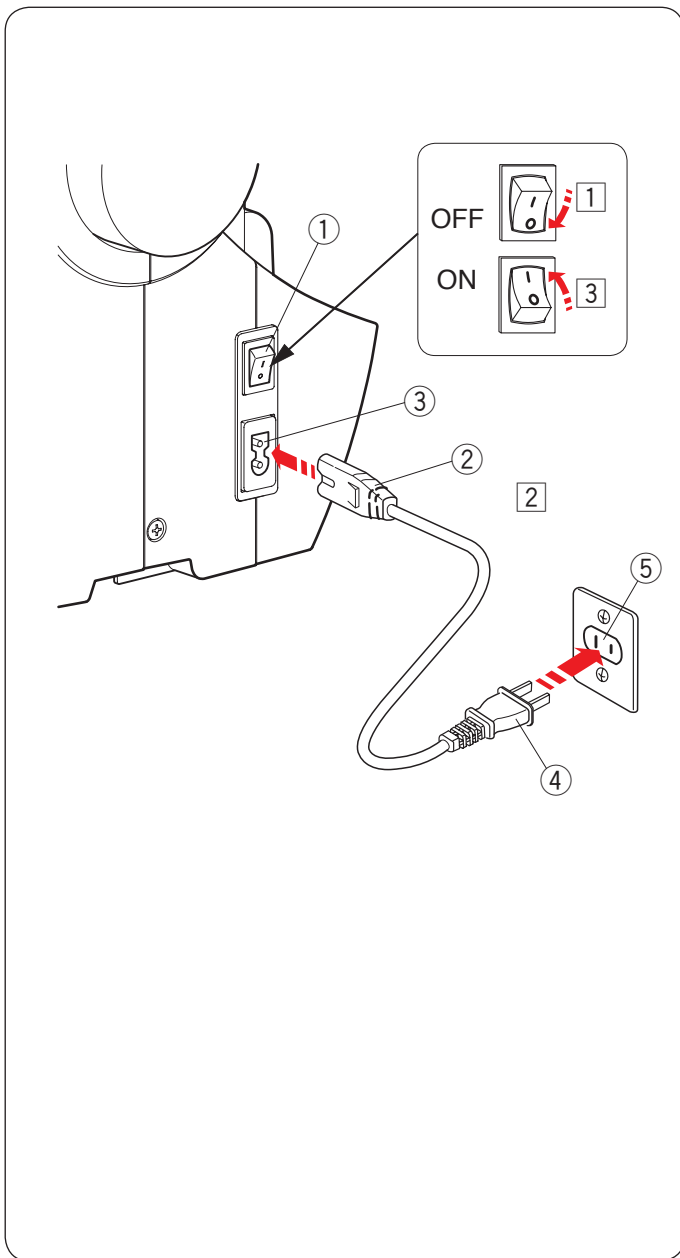

Initializing the Embroidery Machine

Initialize the machine whenever you turn the power switch on.

- 1 Turn the power switch on.
 - ① Power switch

- 2 Raise the presser foot lifter ②.
Turn the handwheel ③ toward you to raise the mark ④ at its highest position. The needle is raised ⑤.
Push the bobbin winder spindle ⑥ to the left.

When the start/stop button ⑦ blinks slowly in orange, you can initialize the machine.

- ② Presser foot lifter
- ③ Handwheel
- ④ Mark
- ⑤ Needle
- ⑥ Bobbin winder spindle
- ⑦ Start/stop button

- 3 Press the start/stop button to initialize the machine.
The carriage will move while initializing the machine.
The start/stop button turns off when the initialization is completed.

WARNING:

- Do not place any obstacle around the machine.
- Keep your hands away from the carriage while it is moving.

Troubleshooting

If the start/stop button blinks slowly in red, that means the machine cannot be initialized.

Be sure that the following conditions are established.

- The presser foot is raised ①.
- The needle is raised ②.
- The bobbin winder spindle ③ is shifted to the left.

The start/stop button blinks slowly in orange when the machine is ready to be initialized.

Press the start/stop button to initialize the machine.

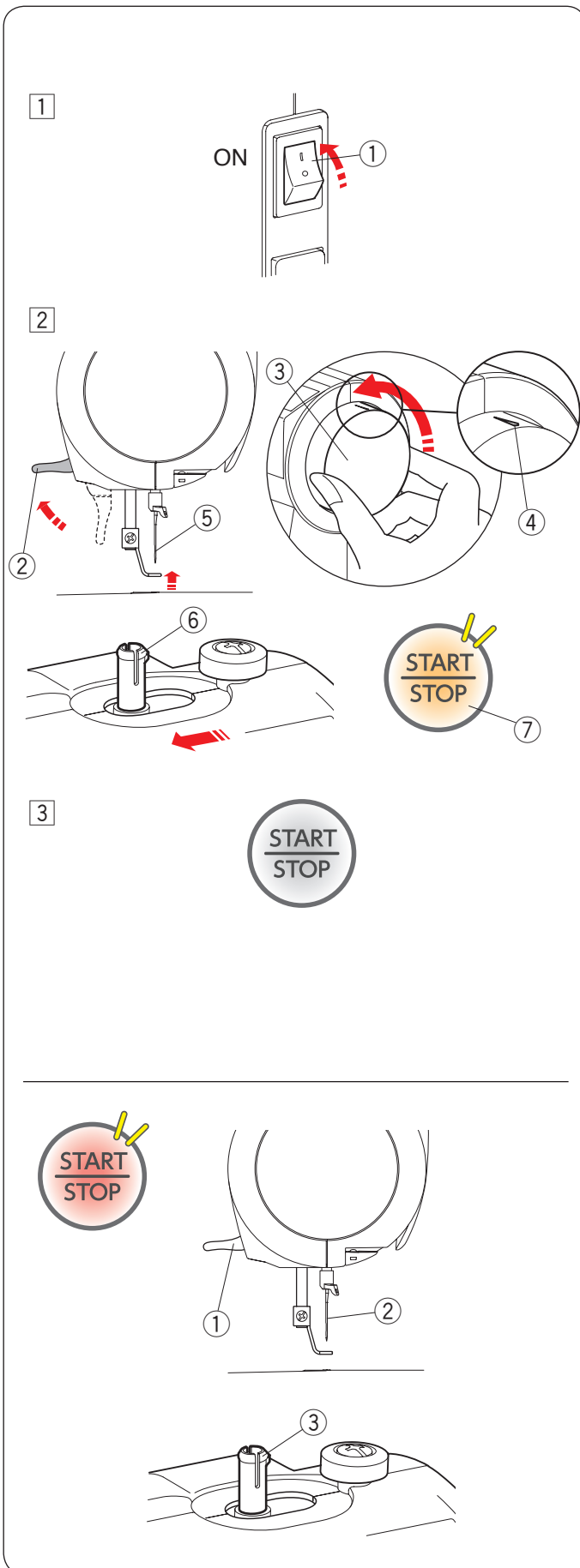

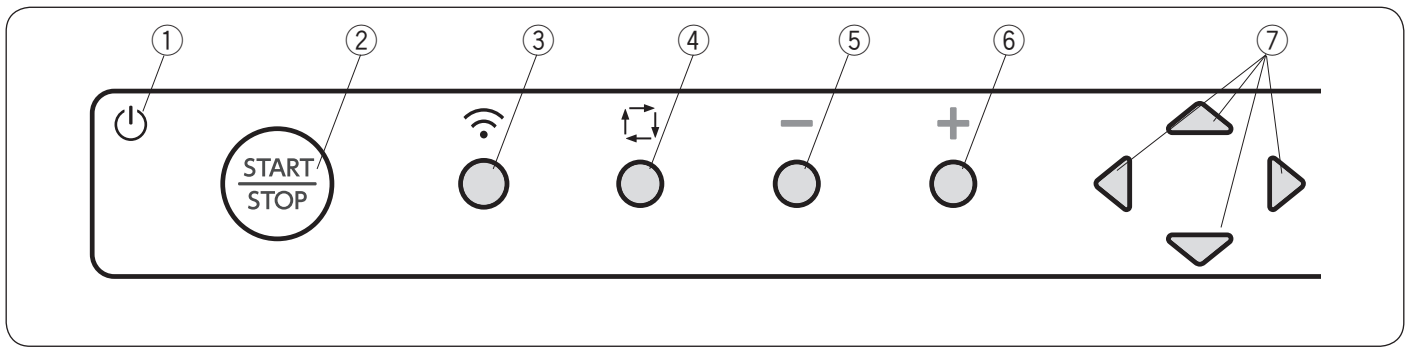

Machine Operating Buttons

① Power light

The power light will be turned on when the machine power is turned on.

The power light will be turned off when the machine power is turned off.

② Start/stop button

Press the start/stop button after turning on the machine to initialize the machine (Refer to page 7).

Press this button to start or stop the machine.

Follow the instructions on the application "dot Customizer" on your tablet or smartphone.

③ Wireless LAN button

The wireless LAN button establishes or terminates the wireless LAN connection (Refer to pages 21, 24-25).

④ Trace button

Press the trace button to check the size of the embroidery area by tracing the pattern outline without stitching (Refer to page 27).

You can also move the hoop to the right back corner with this button when changing threads (Refer to page 33).

⑤ Stitch back button

Press this button to move the hoop back to a previous sewing point.

The hoop will move backward one stitch each time the key is pressed. Hold down the button to travel faster and jump 10, 100 or 500 stitches at a time.

⚠ WARNING:

Do not press the stitch back button too often while sewing. Cut jump threads before pressing stitch back button to prevent the tangling of thread (Refer to page 28).

⑥ Stitch forward button

Press this button to move the hoop ahead.

The hoop will move forward one stitch each time the key is pressed. Hold down the button to travel faster and jump 10, 100 or 500 stitches at a time.

⚠ WARNING:

Do not press the stitch forward button too often while sewing. Cut jump threads before pressing stitch forward button to prevent the tangling of thread (Refer to page 28).

⑦ Jog buttons

You can adjust the hoop position with jog buttons (Refer to page 27).

Before receiving the embroidery data:

You can move the hoop to check the embroidery area.

After receiving the embroidery data:

You can move the hoop to determine the starting point.

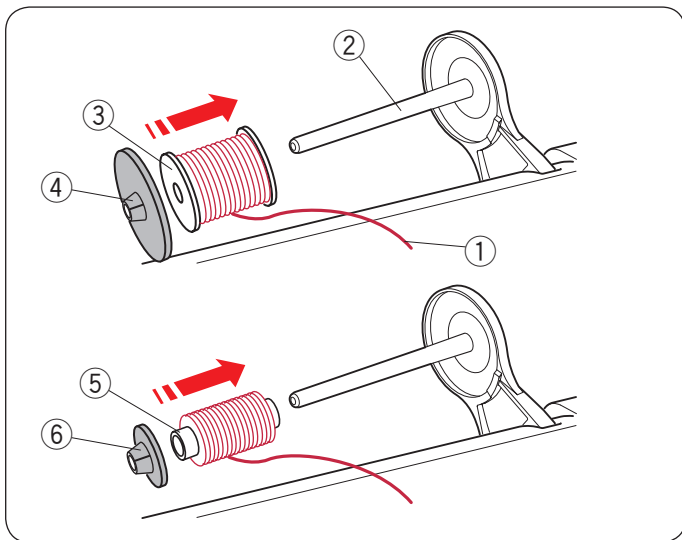

Setting the Spool of Thread

Place the spool of thread on the spool pin with the thread coming off the spool as shown.

Attach the large spool holder, and press it firmly against the spool of thread.

- ① Thread end
- ② Spool pin
- ③ Spool of thread
- ④ Large spool holder

NOTE:

Use the small spool holder to hold narrow or small spools of thread.

- ⑤ Small spool of thread
- ⑥ Small spool holder

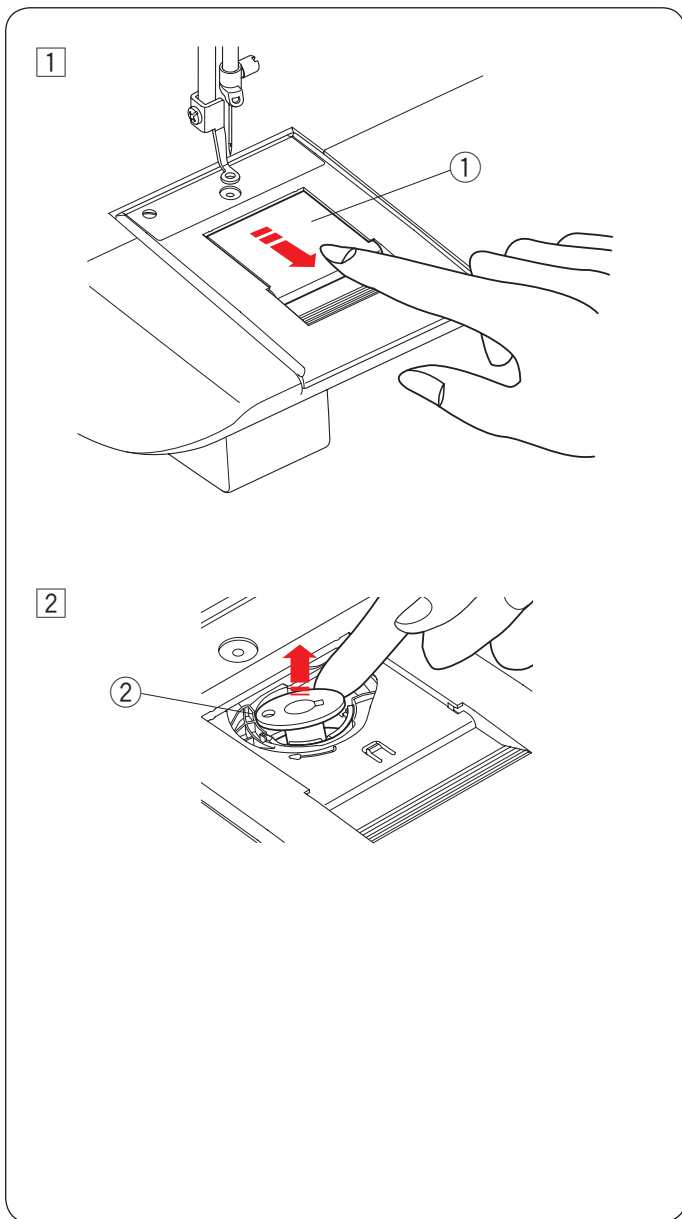

Winding the Bobbin

Removing the Bobbin

- ① Slide the hook cover plate toward you and remove it.

- ① Hook cover plate

- ② Remove the bobbin.

- ② Bobbin

NOTE:

Use the plastic bobbins that come with the machine (Part #102261000). Using other bobbins, such as pre-wound paper bobbins, may cause stitching problems and/ or damage to the bobbin holder.

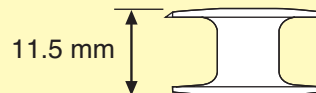

Winding the Bobbin

NOTE:

- Polyester thread (#90-100 (59-53D/66-59dtex))(white) is recommended for bobbin.
- Do not use embroidery thread for bobbin.

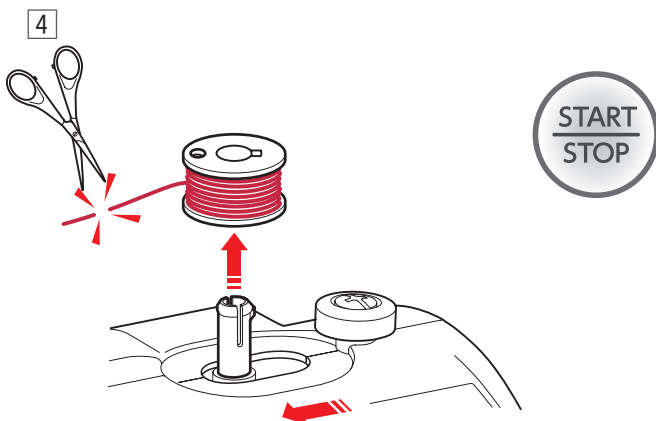
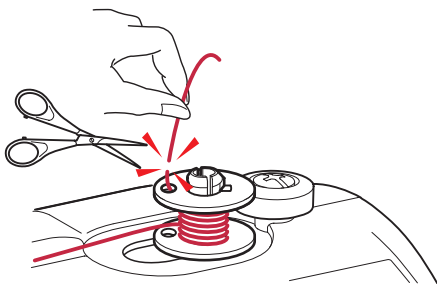
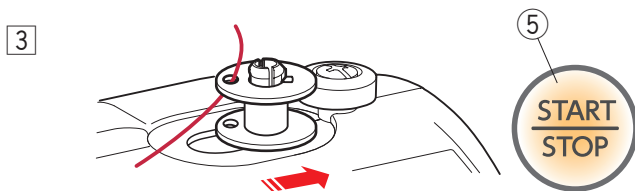
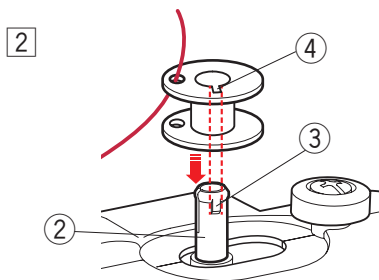
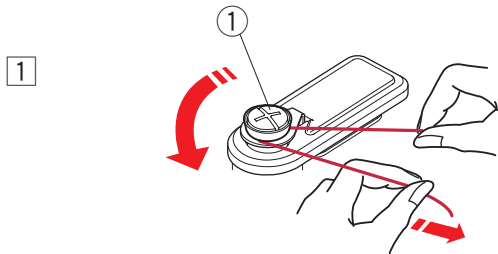
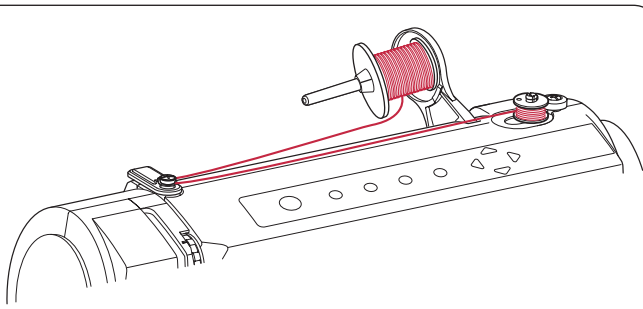

Press the start/stop button to initialize the machine. You cannot wind the bobbin before initializing the machine (Refer to page 7).

- 1 Guide the thread around the bobbin winder thread guide with both hands.
 - 1 Bobbin winder thread guide
- 2 Thread through the hole in the bobbin from the inside to the outside. Align the projection on the bobbin winder spindle and slit of the bobbin. Put the bobbin on the bobbin winder spindle. Be sure that the bobbin snaps into the place.
 - 2 Bobbin winder spindle
 - 3 Projection
 - 4 Slit
- 3 Push the bobbin winder spindle to the right. Press the start/stop button while holding the end of the thread. Stop the machine after the bobbin is wound approximately 3 seconds. Cut the thread close to the hole in the bobbin.
 - 5 Start/stop button

- 4 Press the start/stop button again. When the bobbin is fully wound, it will stop spinning automatically. Press the start/stop button to stop the machine and return the bobbin winder spindle to the left. The start/stop button turns off. Remove the bobbin and cut the thread.

NOTE:

- Do not move the bobbin winder spindle while the machine is running.
- For safety purposes, the machine will automatically stop 90 seconds after starting bobbin winding.

Inserting the Bobbin

NOTE:

Make sure that the bobbin is sufficiently wound.

- 1 Raise the presser foot lifter.
 - ① Presser foot lifter
- 2 Place the bobbin in the bobbin holder with the thread running off counterclockwise.
 - ② Thread
 - ③ Bobbin holder

For bobbin threading, you can refer to the threading chart shown on the hook cover plate.

 - ④ Hook cover plate

- 3 Hold the bobbin with your fingertip so it does not rotate. Guide the thread into the front notch of the bobbin holder.
 - ⑤ Front notch

Pass the thread between the guide and the tension leaf (black blade).

- ⑥ Guide
- ⑦ Tension leaf (black blade)

- 4 Continue to draw the thread lightly until the thread slips into the side notch.
 - ⑧ Side notch

* When drawing the thread, the bobbin will rotate counter-clockwise. If the bobbin rotates clockwise, remove the bobbin and start over from the step 2.

- 5 Pull out about 4" (10 cm) of thread to the rear. Attach the hook cover plate.
 - ④ Hook cover plate
 - ⑨ Thread

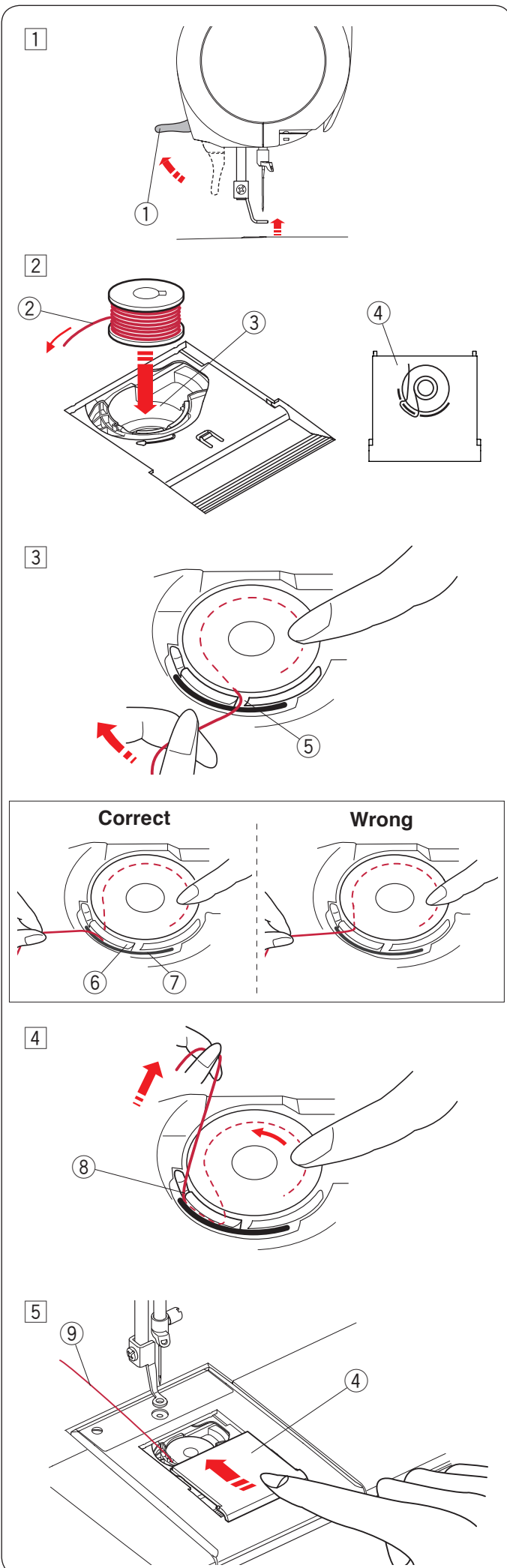

Threading the Machine

- * When threading the machine, hold the thread near the spool with your right hand and draw the thread firmly with your left hand.

Turn the handwheel toward you to raise the mark at its highest position.

Raise the presser foot lifter.

- ① Mark
- ② Presser foot lifter

NOTE:

Raise the presser foot lifter before threading the machine. Otherwise, it may cause thread breakage, maladjustment of thread tension or distorted designs.

Threading the Machine

- ① Draw the thread around and under the thread guide while holding the thread at the spool.

- ③ Thread guide

- ② Draw the thread down through the right channel of the thread tension dial. Pass the thread under the thread guide plate and draw it up to the left.

- ④ Thread guide plate

- ③ Pass the thread through the eye of the take-up lever from the right to the left.

- ⑤ Eye of take-up lever

- ④ Draw the thread down along the left channel. Pass the thread through the eye of the needle bar thread guide as shown.

- ④ Thread guide plate
- ⑥ Needle bar thread guide

- * Use the handy threader to threading the needle (Refer to page 13).

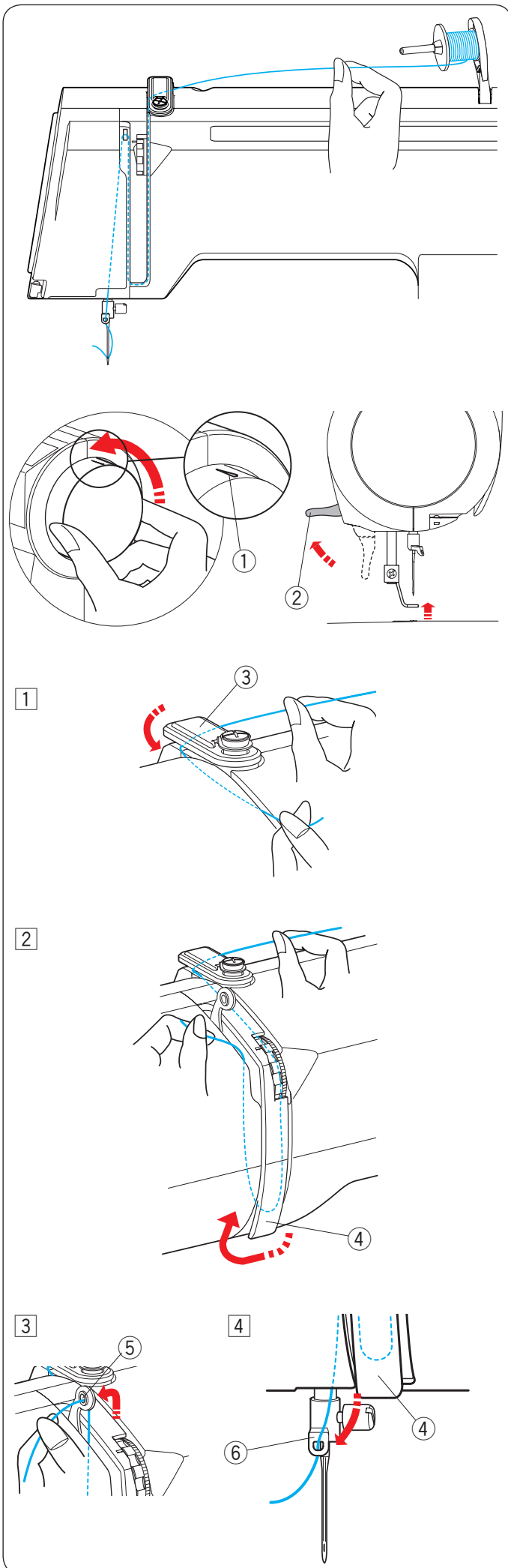

Handy Threader

* Turn off the power switch of the machine before using the Handy Threader.

* Do not use the threader for other than threading.

- ① Stem
- ② Triangle mark
- ③ Y-cut
- ④ V-cut
- ⑤ Hook

How to thread the needle

- ① Hold the stem of the threader with the triangle mark up. Guide the thread to insert it into the Y-cut from the right to the left.

- ① Stem
- ② Triangle mark
- ③ Y-cut

- ② Place the V-cut over the needle just above the needle eye. Make sure the thread does not slip out from the Y-cut.

- ④ V-cut

- ③ Slide the threader down along the needle while pushing it gently until the threader pin goes into the needle eye.

- ⑥ Needle eye

- ④ Push the stem so that the threader pin comes out through the needle eye with a loop of thread.

- ⑤ Remove the threader from the needle slowly, leaving the thread loop behind the needle eye. Then pick the loop with the hook to pull out the end of thread to the back.

- ⑤ Hook

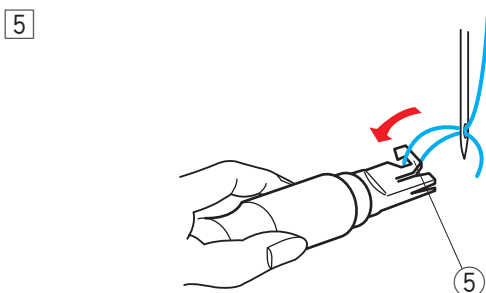
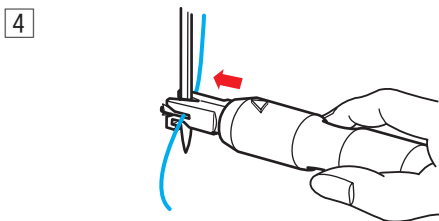
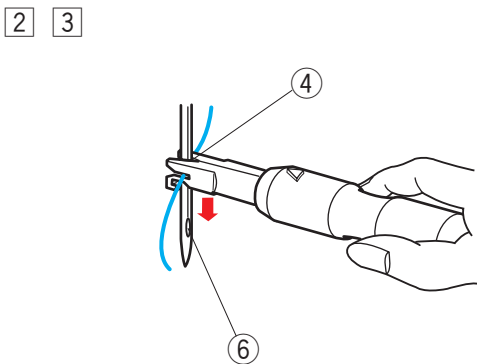
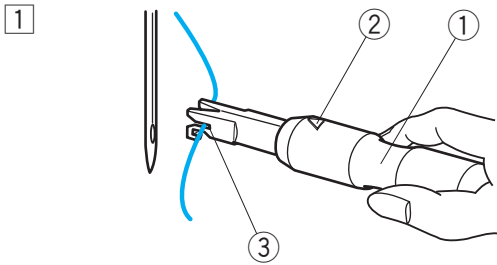
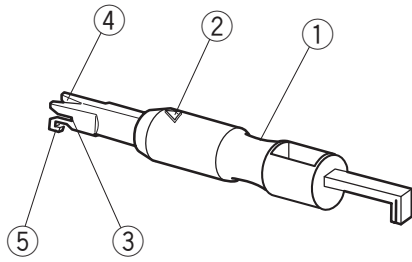

Drawing Up the Bobbin Thread

1

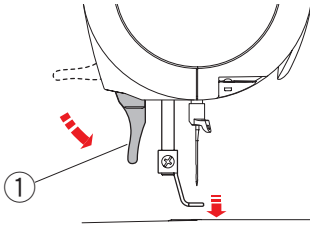

- 1 Lower the presser foot lifter.
Hold the needle thread lightly with your left hand.

- ① Presser foot lifter
- ② Needle thread

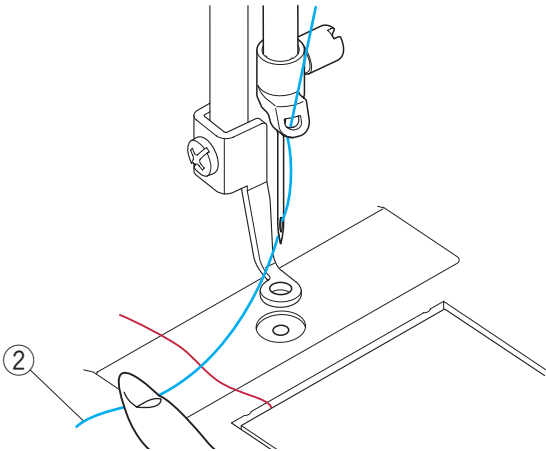

2



- 2 Turn the handwheel towards you for 1 full rotation.
Draw the needle thread to bring up a loop of the bobbin thread.

- ② Needle thread
- ③ Bobbin thread

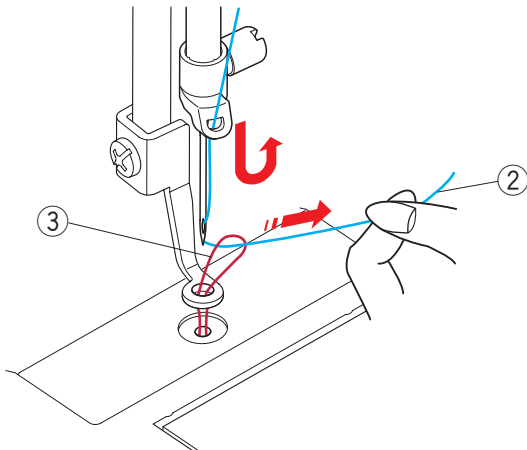

3

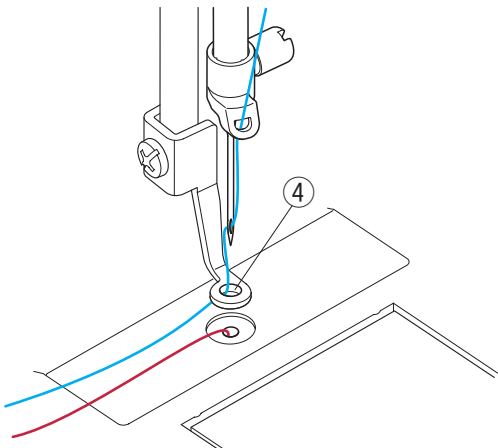

- 3 Draw the bobbin thread from the hole of the needle plate to under the foot.
Pass the needle thread through the hole of the presser foot.

- ④ Hole of presser foot

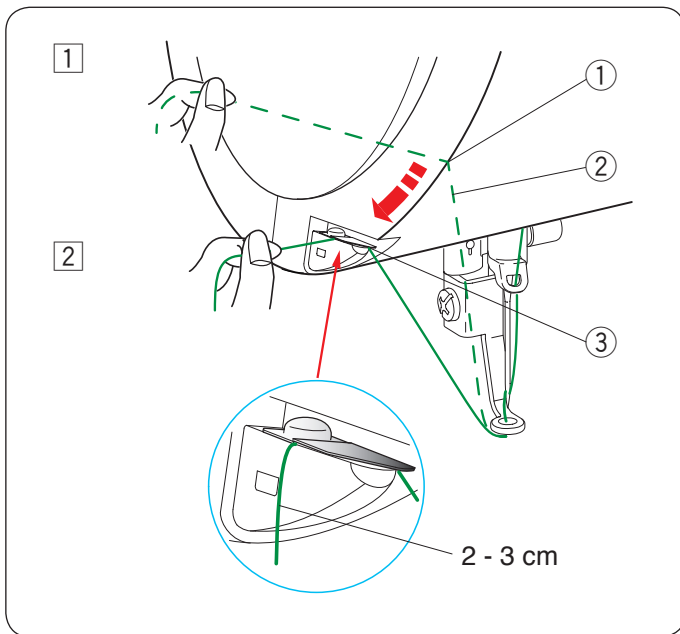

Sliding the needle thread into the thread holder
Slide the needle thread into the thread holder to prevent the thread getting caught in the embroidery.

- 1 Pull the needle thread up and to the left. Slide the needle thread along the edge of the face plate as shown.
 - 1 Edge of face plate
 - 2 Needle thread
- 2 The needle thread will slide into the slit of the thread holder.
 - 3 Slit
 Draw the thread end 3 cm (1") to the back.

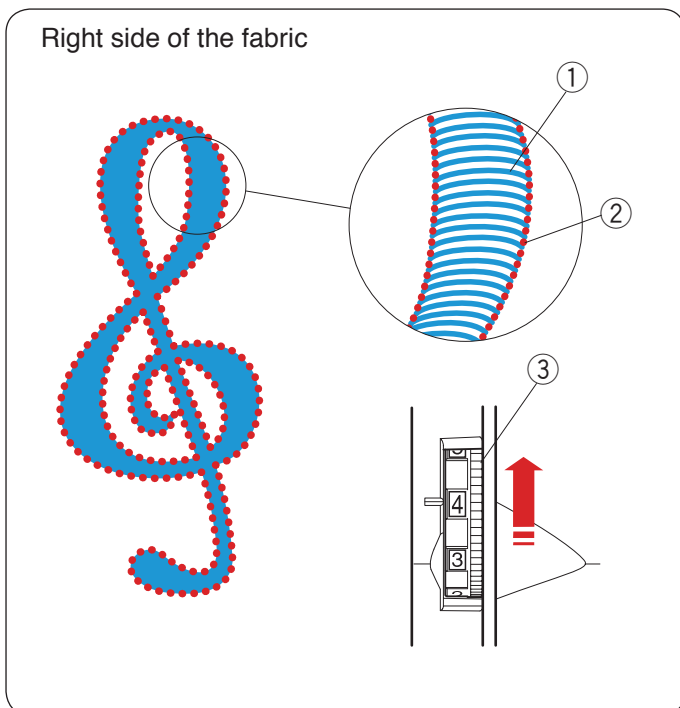

Adjusting the Needle Thread Tension

When the needle thread tension is too tight, the bobbin thread shows on the right side of the fabric.

Reduce the thread tension by turning the tension dial to a lower number.

- 1 Needle thread (blue)
- 2 Bobbin thread (red)
- 3 Thread tension dial

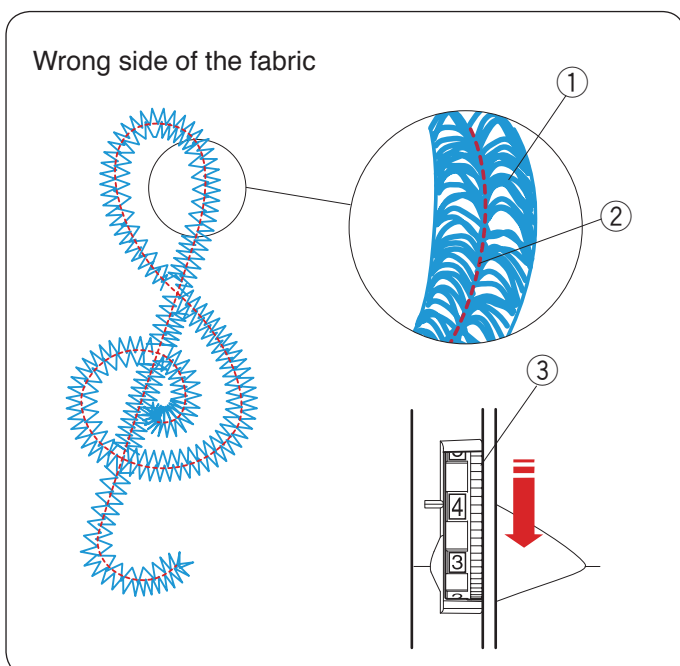

When the needle thread tension is too loose, the needle thread shows on the wrong side of the fabric.

The needle thread forms loops and the stitches look shaggy.

Increase the tension by turning the dial to a higher number.

- 1 Needle thread (blue)
- 2 Bobbin thread (red)
- 3 Thread tension dial

Embroidery Hoop

Embroidery hoop SQ10c

A square embroidery hoop with a 102 mm (4.0") square embroidery area.

Prepare a stabilizer larger than the embroidery hoop.

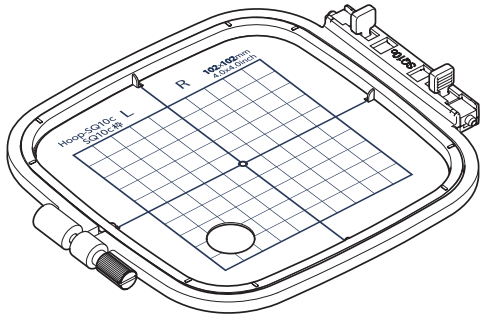

Stabilizer

To create the best quality embroidery, it is important to use stabilizers.

① Stabilizer

* Make sure to use a stabilizer when embroidering a fine fabric or a synthetic fabric.

The non-adhesive type should be used when embroidering fabric which cannot be ironed or for sections which are difficult to iron.

Attaching the stabilizer

Place the wrong side of fabric and the glossy side of the stabilizer together. Fold up a corner of the stabilizer and fuse it with an iron.

② Wrong side of fabric

Cover the fabric with a cloth when ironing.

③ Cloth

Fold up a corner of the stabilizer

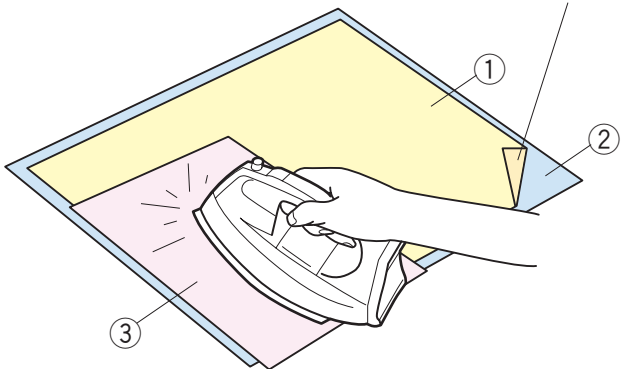

NOTE:

- Ironing temperatures vary depending on the kind of adhesive stabilizer you are using.
- Fold up a corner of the stabilizer, to make it easier to peel off the excess stabilizer after stitching.
- Stabilizer is not included with this machine.
- Attach a stabilizer or make a hooping fabric for a stretch fabric such as jersey or smooth knit. Please refer to the online help FAQ.

⚠ WARNING:

Always test sew on a scrap piece of fabric that you wish to use.

Be extra cautious when sewing on materials such as denim or thick leather.

Avoid sewing on the folded or overlapped fabric as illustrated below.

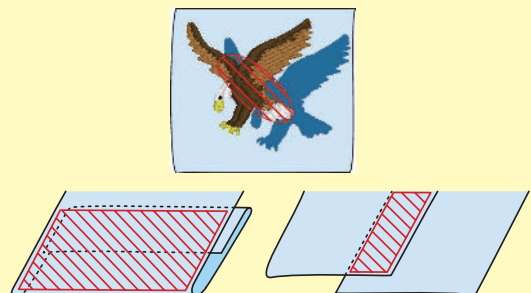

Template

Use the template to determine the position to embroider the design.

NOTE:

- Print template sheets of the desired design by using the online help "Template sheet".
- Be sure to print the template sheet at "actual size".

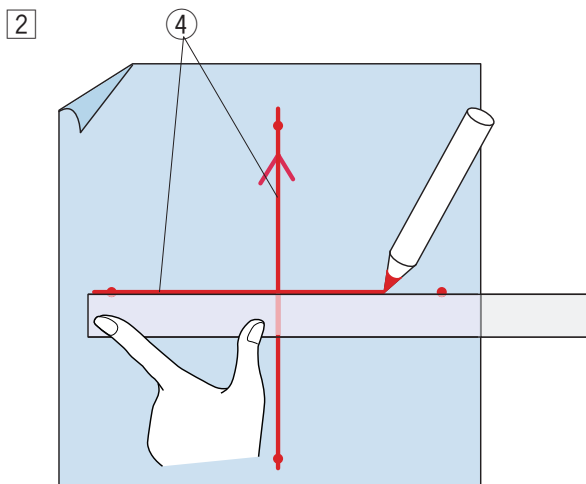
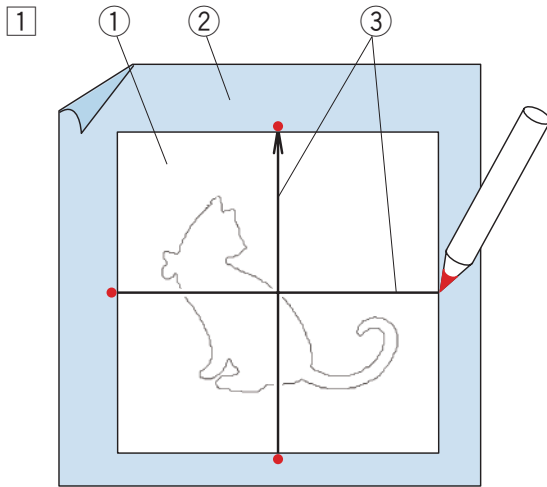

- 1 Cut the template sheet according to the size of the design. Place the template sheet on the right side of fabric where you would like to embroider. Mark 4 dots at the end of the positioning lines with a marker*.

- 1 Template sheet
- 2 Right side of fabric
- 3 Positioning line of template

* A water-erasable marker works best.

- 2 Draw the centerlines on the fabric by connecting the dots.

Add the arrow mark on the centerlines as shown.

- 4 Centerlines

Setting the Fabric in the Embroidery Hoop

- 1 Draw the centerlines on the fabric with a tailor's chalk. Prepare a fabric larger than the embroidery hoop.

- ① Fabric
- ② Centerlines

- 2 Lay the inner hoop and template on the fabric, matching the centerlines of the fabric with the positioning lines of the template.

- ③ Inner hoop
- ④ Template

- 3 Loosen the hoop tightening screw of the outer hoop. Place the inner hoop and fabric on the outer hoop.

- ⑤ Hoop tightening screw
- ⑥ Outer hoop

- 4 Tighten the screw on the outer hoop to stretch the fabric. Without loosening the hoop tightening screw, remove the inner hoop and push it back into the outer hoop to tighten the fabric.

Pull the 4 edges of the fabric to stretch it drum-tight. Do not pull a stretch fabric too tight.

- ③ Inner hoop
- ④ Template
- ⑤ Hoop tightening screw

- 5 Remove the template.

- ⑦ Hole of template

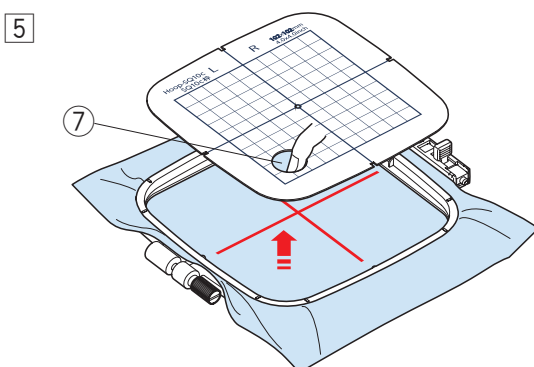
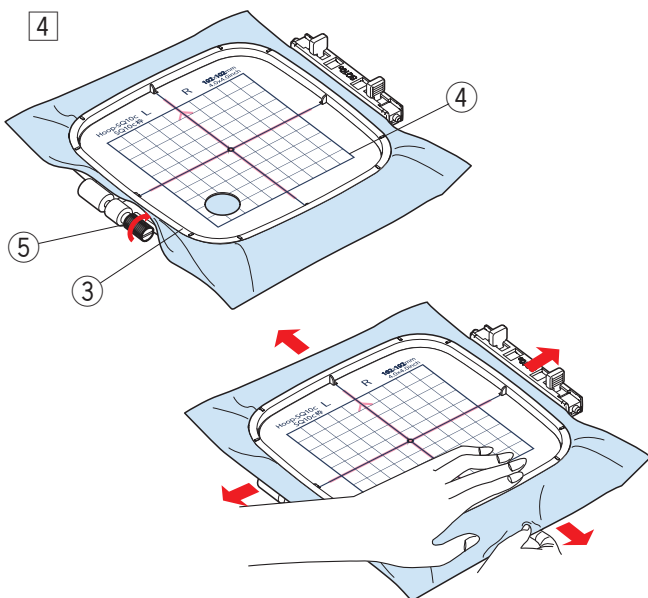
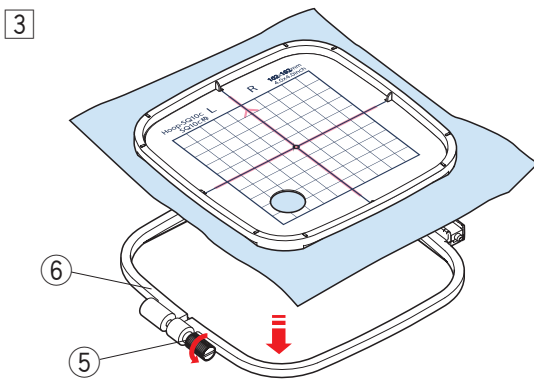
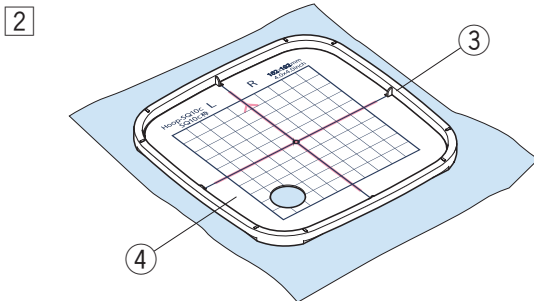
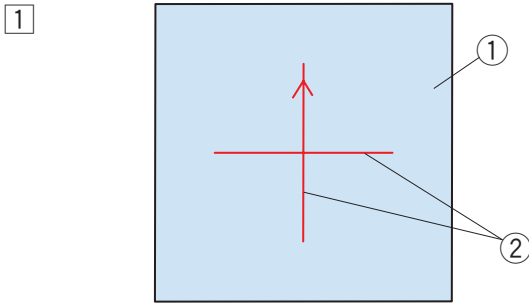

Attaching the Embroidery Hoop to the Machine

- 1 Turn the handwheel toward you to raise the mark at its highest position.
Raise the presser foot lifter to the extra lifted position.
 - 1 Mark
 - 2 Presser foot lifter

- 2 Place the embroidery hoop and fabric under the presser foot.
 - 3 Lever
 - 4 Hoop pin
 - 5 Carriage
 - 6 Carriage hole

- 3 Hold the levers and shift them in the direction of the arrows as shown.
 - 3 Lever
- 4 Holding levers, attach the hoop in the carriage.
- 5 Insert the hoop pins in the carriage holes by releasing levers to secure the hoop.
Be sure that the hoop pins come out from the carriage holes.
 - 4 Hoop pin

⚠ WARNING:

- Be careful not to place the excess of fabric between the carriage and machine body. Otherwise, it may cause breakage or malfunction.
 - 1 Gap between the carriage and machine body
- Never try to move the carriage by hand or touch the carriage while it is moving.
Otherwise, it may cause breakage or malfunction.

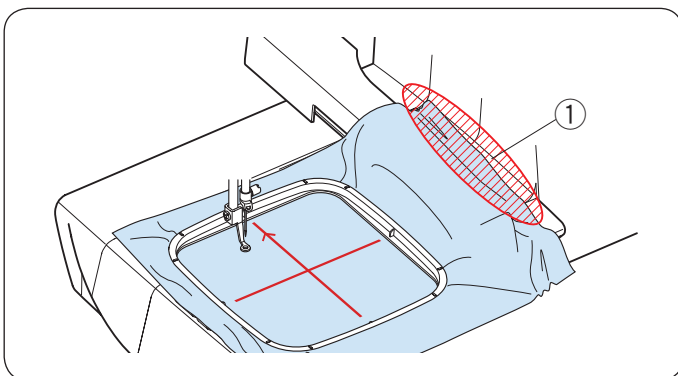
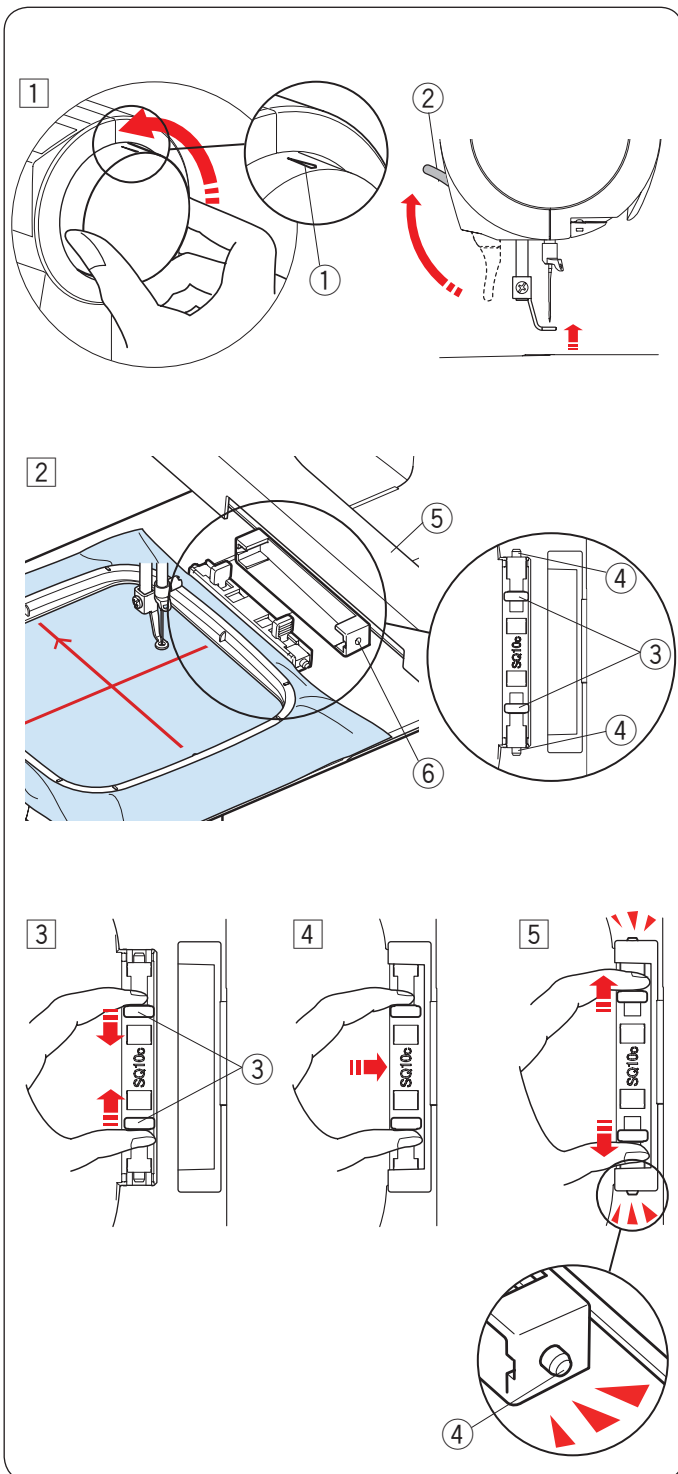

Removing the Embroidery Hoop from the Machine

- 1 Turn the handwheel toward you to raise the mark at its highest position.
Raise the presser foot lifter to the extra lifted position.
 - 1 Mark
 - 2 Presser foot lifter

- 2 Holding levers, remove the hoop.
 - 3 Lever

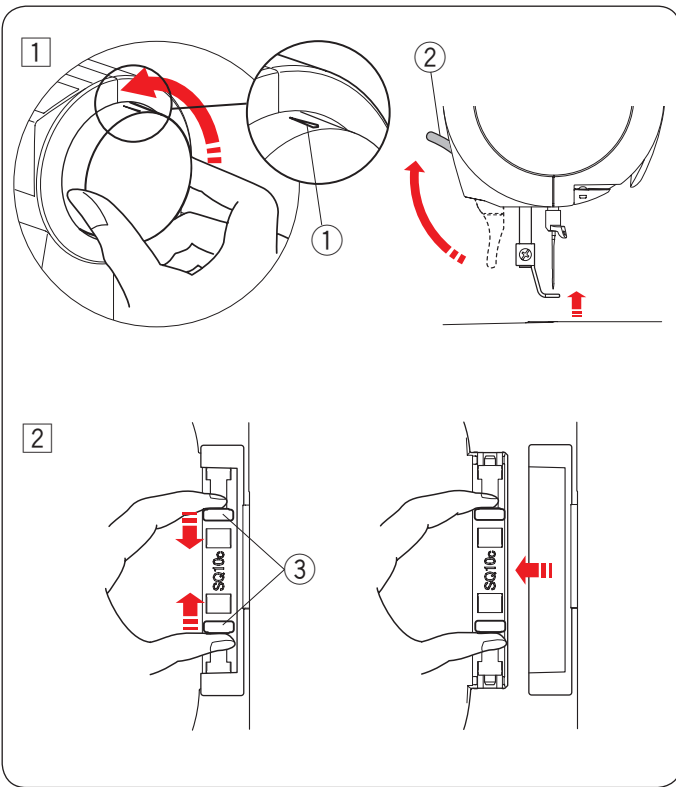

Connecting the embroidery machine to your device

You can connect your smart device (iOS or Android OS) with the embroidery machine with or without a wireless LAN router.

Access point mode



Access point mode:

You can connect your smart device with the embroidery machine directly without a wireless LAN router. The default setting of the wireless LAN connection mode is access point mode.

The wireless LAN light blinks slowly in the access point mode.

NOTE:

You cannot use e-mail/internet while communicating with your embroidery machine in the access point mode. Disconnect your device from the embroidery machine when you want to use your device to connect to the internet.

Client mode



Client mode:

You can connect your smart device with the embroidery machine via a wireless LAN router.

You can use e-mail/internet with your smart device while communicating with your embroidery machine in the client mode.

The wireless LAN light will turn on when connecting the machine in the client mode.

- ① Wireless LAN light (turns on)

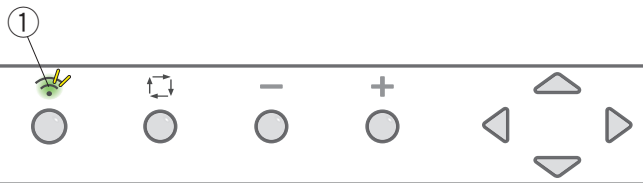
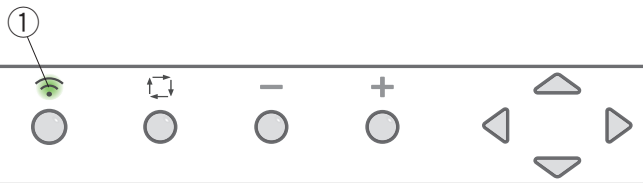

It will take approximately 1 minute to start communicating after turning on the machine.

The wireless LAN light blinks rapidly before start communicating.

- ① Wireless LAN light (blinks rapidly)

In access point mode, the wireless LAN light will start blinking slowly when connected to your device.

In client mode, the wireless LAN light turns on when connected to your device.

- iOS is the name of the operating system software created by Apple Inc.
- iOS is a trademark of Cisco Systems Inc. registered in the U.S. and other countries and is used under license.
- Android and Google Play are trademarks of Google LLC.

Access Point Mode Settings

iPad / iPhone:

NOTE:

The version of iOS described in this manual is "11.3".
Wi-Fi connection method may vary depending on the version of OS.

Press the start/stop button to initialize the machine. You cannot set the access point mode without initializing the machine (Refer to page 7).

- From the home screen on your iPad/iPhone, tap "Settings" icon.
Tap "Wi-Fi".
Swipe the toggle switch to ON.
① Setting icon

- Tap the network name of the embroidery machine (For example: MAC address/ JANOME-xx-xx-xB).

NOTE:

The MAC address is printed on the sticker on the rear side of the machine.

- MAC address

- Enter the password "12345678".
Tap "Join".

- Once the machine is connected, the check mark appears next to the name of network, and the Wi-Fi mark will be displayed in the status bar.
③ Wi-Fi mark

- iPad and iPhone are trademarks of Apple Inc., registered in the U.S. and other countries.
- Wi-Fi is a registered trademark of the Wi-Fi Alliance.

1

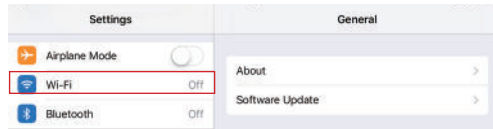
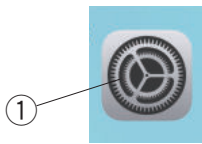

2

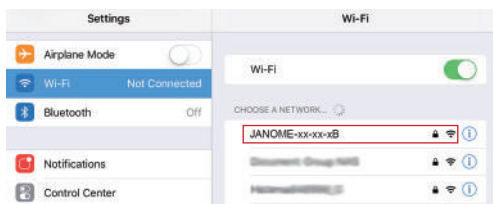

Upper: For the client mode

MAC:08EA40xxxxxA
MAC:08EA40xxxxxB

Lower: For the access point mode

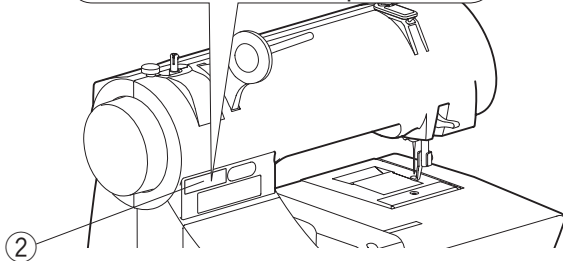

3

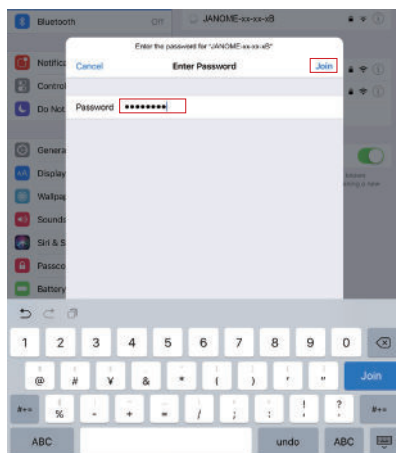

4

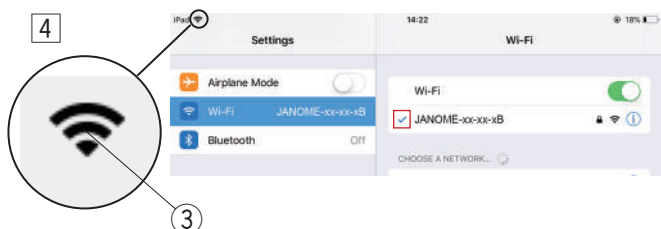

Android OS tablet or smart phone:

NOTE:

The Wireless LAN setup for Android devices can vary depending on the smart device you are using. Refer to the instruction manual of your Android device for how to connect wireless LAN connection with your smart device.

Press the start/stop button to initialize the machine. You cannot set the access point mode without initializing the machine (Refer to page 7).

- 1 From the home screen on your smart device, tap "Settings".
Be sure that "Wireless and Network" or "Wi-Fi" is turned "ON". If not, enable the switch.
- 2 Tap "Wireless and Network" or "Wi-Fi".
Tap the network name of the embroidery machine (For example: MAC address/ JANOME-xx-xx-xB).

NOTE:

The MAC address is printed on the sticker on the rear side of the machine.

- ① MAC address

- 3 Enter the password "12345678".
Tap "Connect".
- 4 Once the machine is connected, the Wi-Fi mark will be displayed in the status bar.

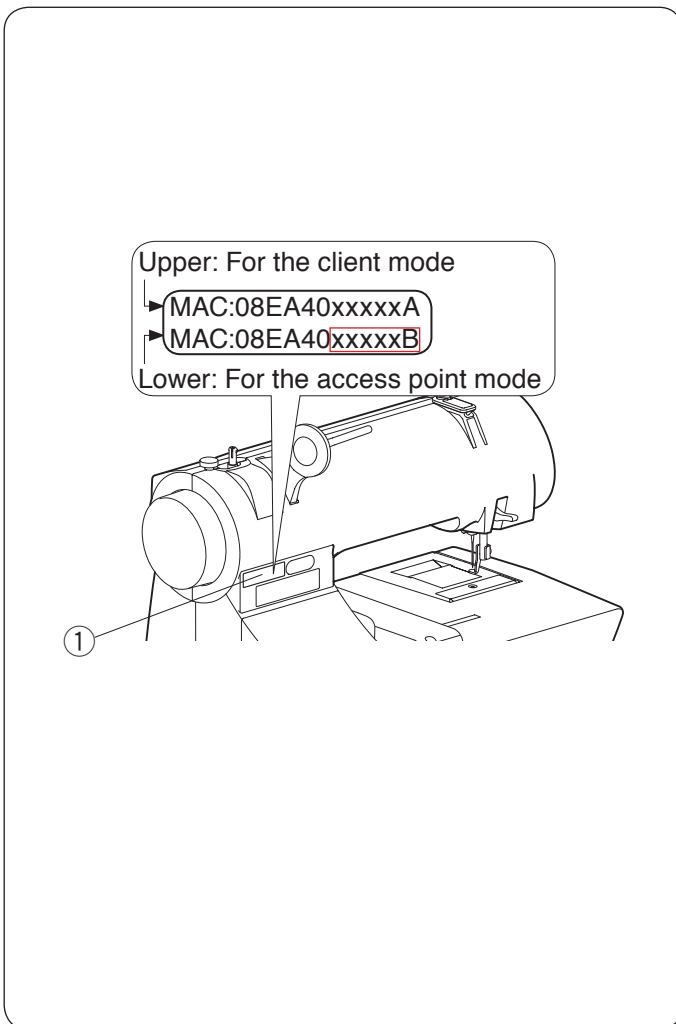

Client Mode Settings

A wireless router device that complies with the IEEE802.11b/g/n wireless standard is required for connecting your machine with a wireless LAN network.

The wireless LAN light will turn on when connecting the machine in the client mode.

- ① Wireless LAN light

NOTE:

The use of home appliances such as a microwave oven, bluetooth devices or cordless phones can reduce the range of the wireless LAN connection (if your wireless router's network standard is using IEEE802.11b or IEEE802.11g).

You may need to reduce the distance between your machine and the wireless LAN access point, or install the wireless LAN access point at an appropriate location.

Push-button method

You can connect the machine to the wireless router without entering SSID or password by pressing push-button.

To use the Push-button method, the wireless router must support this method. Please also refer to the wireless router's instructions about this method.

The name of "Push button" may vary depending on the router.

Press the start/stop button to initialize the machine. You cannot set the access point mode without initializing the machine (Refer to page 7).

- ① Press and hold the wireless LAN button ② and the jog button "▶" ③ more than 3 seconds.
The wireless LAN light blinks rapidly.

② Wireless LAN button

③ Jog button (right)

④ Wireless LAN light (blinks rapidly)

- ② Press the Push button on the wireless LAN router.
The wireless LAN router will automatically connect with your machine.

- ③ Wireless LAN light turns on when connecting the machine in the client mode.

④ Wireless LAN light (turns on)

* The connection failed if the wireless LAN light does not turn on. Start over the step from ①.

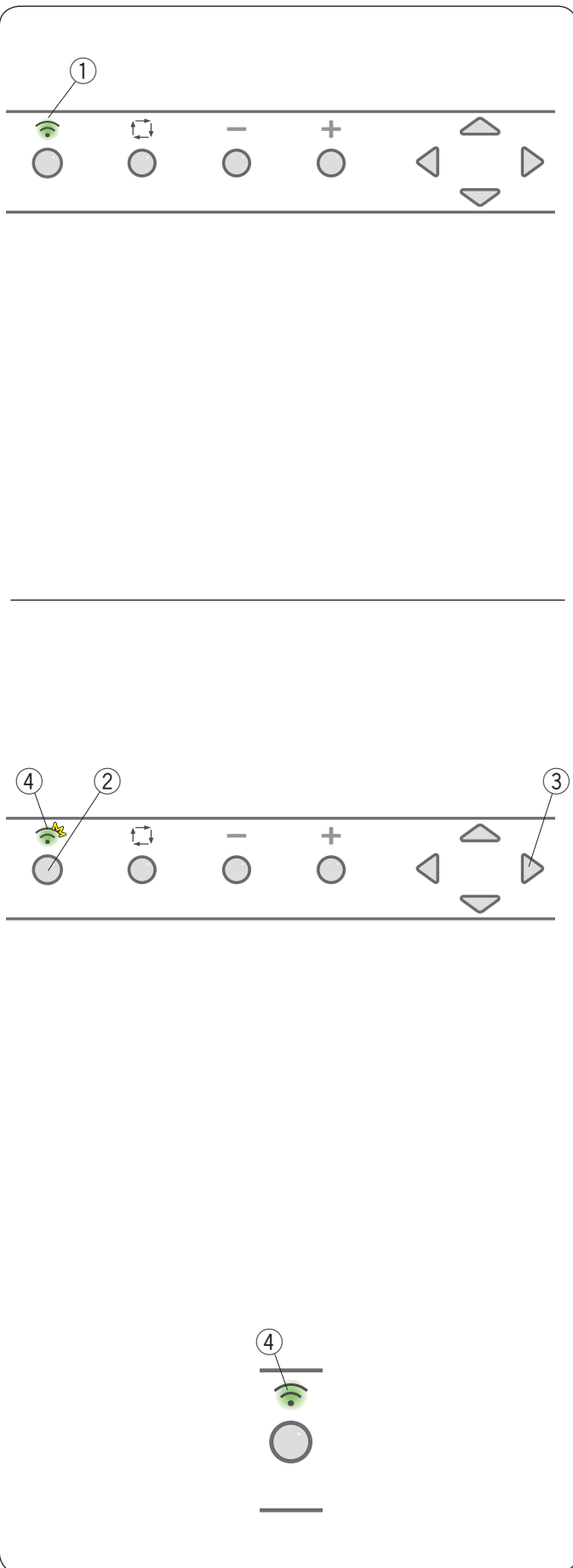

Change the connection method from the application
Connect your smart device with the embroidery machine in access point mode (Refer to pages 22-23).

1 Display the confirmation screen (Refer to page 26). Tap the Machine Settings icon on the right upper corner.

① Setting icon

2 Tap "Client" to switch to the client mode. Enter the SSID and the password for the wireless LAN router and tap "Apply". The wireless LAN router and the embroidery machine will be connected.

* Refer to the instruction of the wireless LAN router for the SSID and the password.

3 The wireless LAN light will turn on when the machine is switched to the client mode.

② Wireless LAN light

NOTE:

If the embroidery machine failed to switch the mode, the rapid blinking of the wireless LAN light become slow and it returns to the access point mode automatically.

Restart steps from 1.

If the wireless LAN light keeps blinking rapidly or turns off, switch the embroidery machine from the client mode to access point mode, and restart steps from 1.

Switching the mode from the client mode to access point mode

Press and hold the wireless LAN button and stitch back button at the same time more than 3 seconds.

The wireless LAN light starts blinking slowly when the mode is switched.

Turn the Wi-Fi ON of your smart device.

Tap the network name of the embroidery machine, and enter the password "12345678" (Refer to page 22-23).

- ① Wireless LAN button
- ② Stitch back button
- ③ Wireless LAN light

NOTE:

The MAC address is printed on the sticker on the rear side of the machine.

④ MAC address

The wireless LAN settings will not change after turning OFF the machine.

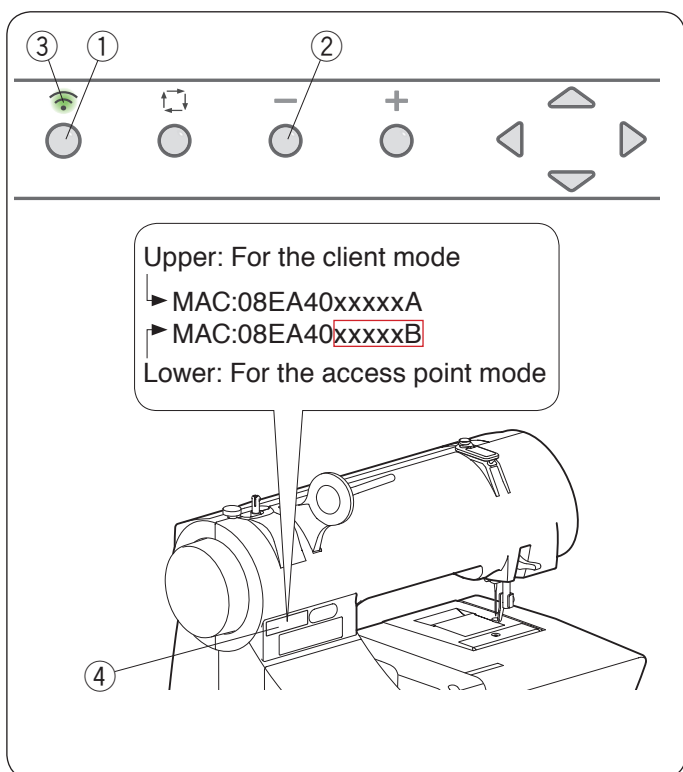
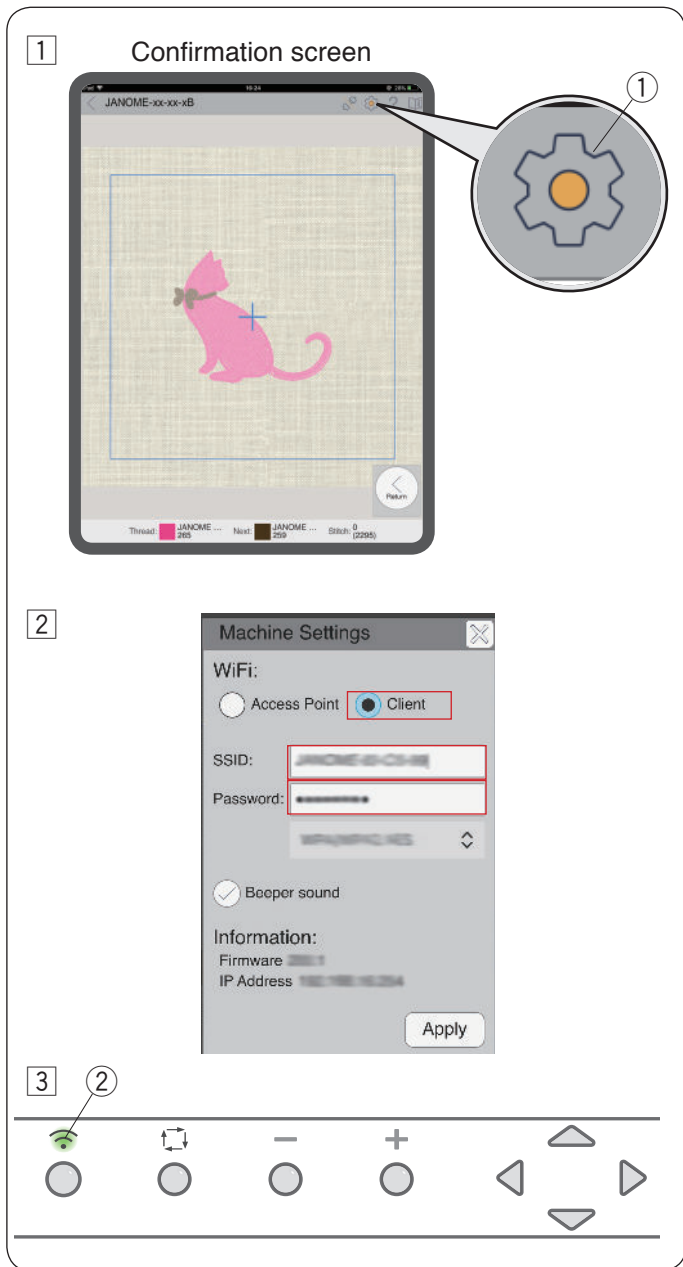

Sending the Designs to the Embroidery Machine

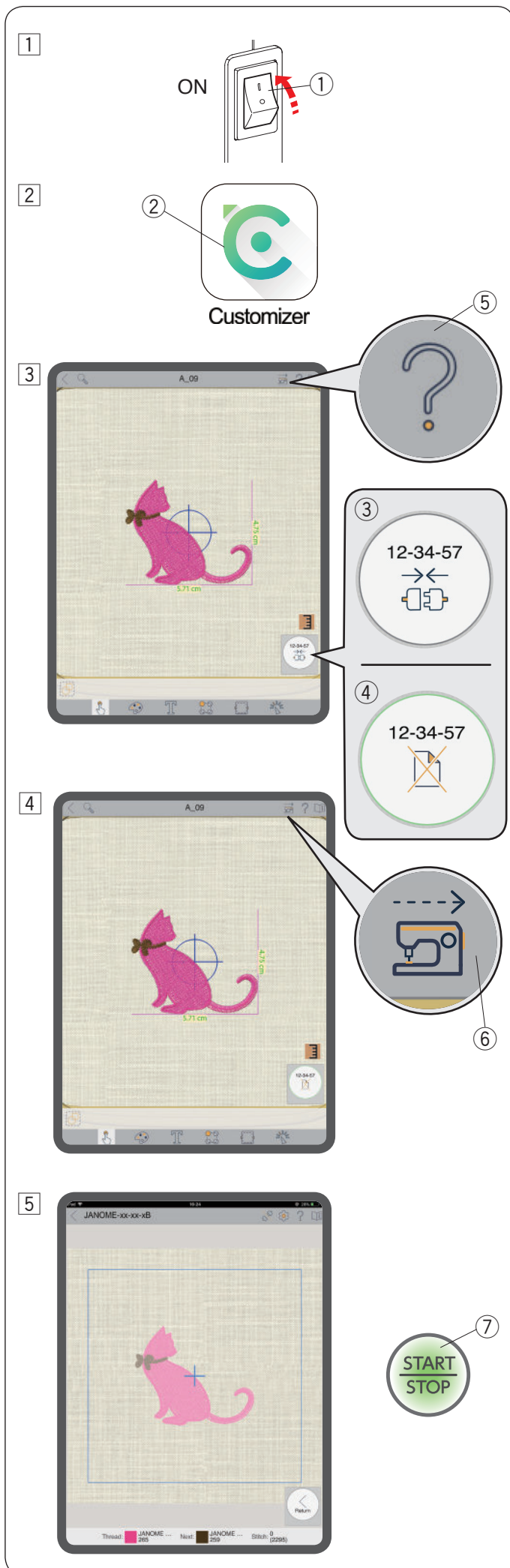

1 Turn the power switch ON.
Press the start/stop button to initialize the machine. You cannot send designs to the machine without initializing the machine (Refer to page 7).

① Power switch

2 Launch the application "dot Customizer".

② "dot Customizer" icon

3 Select the desired embroidery design and edit it.
Tap the "Press to connect" icon on the lower right corner to connect to the embroidery machine.

③ "Press to connect" icon

④ "Press to disconnect" icon

Tap the "Help" icon on the upper right corner to show the hint of each icons.

⑤ "Help" icon

When changing the size of built-in designs in the application, set the scale in the range of 80% - 120%. Exceeding the range may distort the design.

⚠ WARNING:

- Do not set the scale of embroidery designs less than 80%. This may cause breaking of thread or needle to break.
- When embroidering designs imported from outside the app, carry out a test-sew first. Designs must fit in 102 mm X 102 mm / 4" X 4" hoop.
- Do not embroider over other embroidery designs. This may cause breakage of thread or needle.

4 Tap the "Send Design to Machine" icon on the right upper corner to send design to the embroidery machine.

⑥ "Send Design to Machine" icon

NOTE:

You cannot send embroidery designs to the embroidery machine under following conditions.

- The embroidery machine is not initialized (Refer to page 7).
- The bobbin winder spindle is not shifted to the left (Refer to page 7).

5 The screen change to the confirmation screen.
The Start/stop button turns on in green.

⑦ Start/stop button

Starting to Sew Embroidery

Basic Sewing

- ① Adjust the hoop position with the jog buttons so that the needle position comes right above the center of the centerlines on the fabric.

① Jog buttons

* The jog buttons will not work under the following conditions.

- The presser foot lifter is lowered.
- The needle is lowered.
- The bobbin winder spindle is not returned to the left.

⚠ WARNING:

Do not place any obstacles around the machine where embroidery hoop moves.

Otherwise, it may cause injury, malfunction or distorted designs.

- ② When the trace button light is turned on in green, you can check the size of the embroidery area by pressing the trace button.

② Trace button light

③ Trace button

* The trace button will not work under the following conditions.

- The presser foot lifter is lowered.
- The needle is lowered.
- The bobbin winder spindle is not returned to the left.

⚠ WARNING:

Do not place any obstacles around the machine where embroidery hoop moves.

Otherwise, it may cause injury, malfunction or distorted designs.

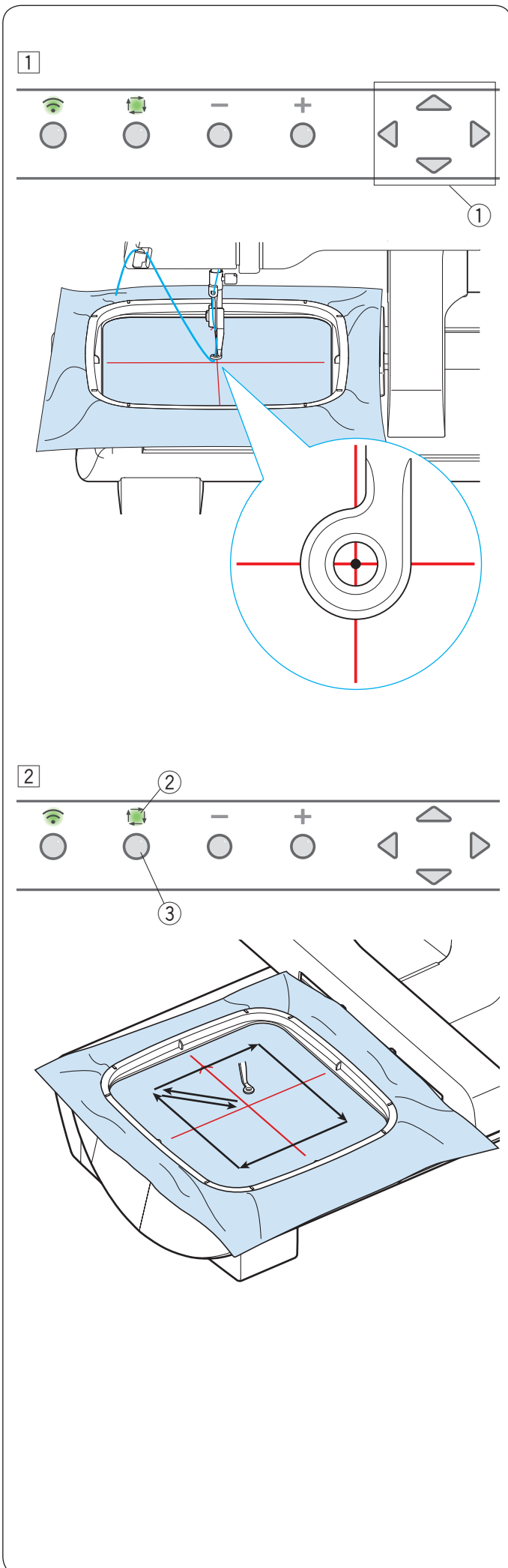

3

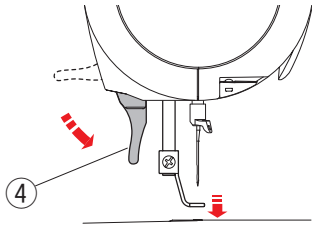

* Hook the needle thread

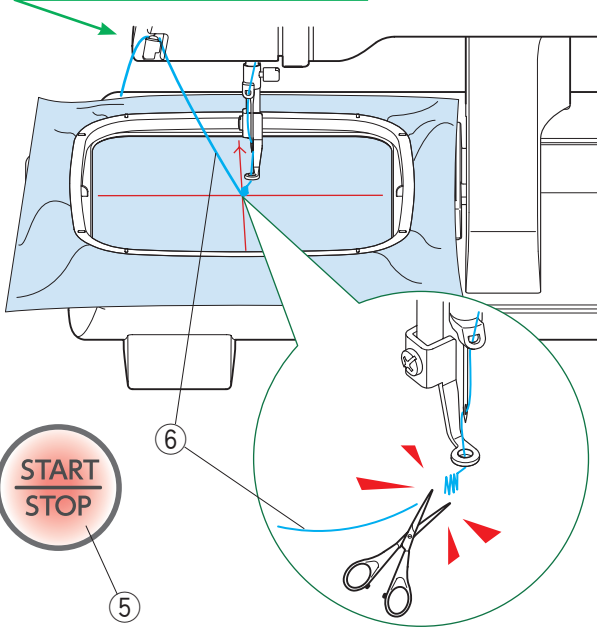

4

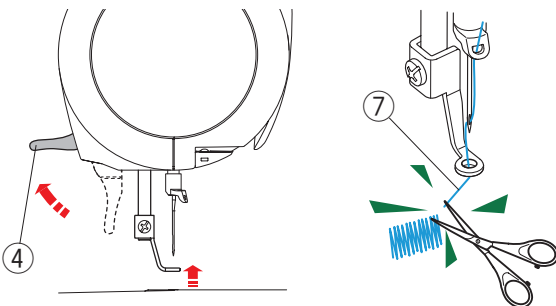

5

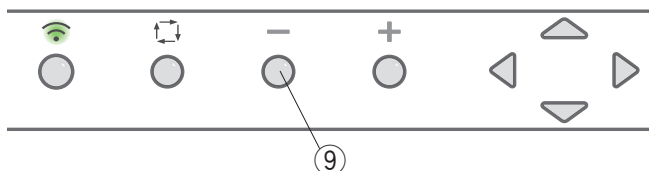
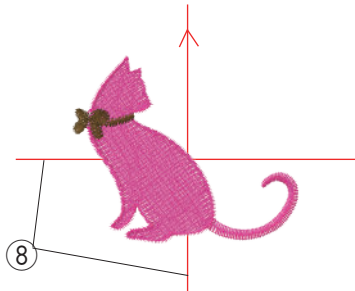

- 3 Lower the presser foot lifter. Hook the needle thread to the thread holder and press the start/stop button. Sew 5 to 6 stitches and press the start/stop button to stop the machine. Cut the loose thread close to the beginning of the starting point.
- ④ Presser foot lifter
 - ⑤ Start/stop button
 - ⑥ Loose thread

⚠ WARNING:

While in operation, always keep your eyes on the sewing area, and do not touch any moving parts such as the thread take-up lever, handwheel or needle.

Always turn off the power switch and unplug the machine from the wall outlet:

- when leaving the machine unattended.
- when attaching or removing parts.
- when cleaning the machine.

NOTE:

- Hook the needle thread to the thread holder. Start to sew 5 to 6 stitches. Otherwise the needle thread may get tangled on the wrong side of the fabric.
- Do not turn the handwheel forcibly when the machine stops for tangling of threads. Cut the tangled threads on the wrong side of the fabric, and remove the hoop from the machine (Refer to page 37). If you cannot remove the tangled threads, contact the service center or the store from whom the machine was purchased.

- 4 Press the start/stop button to start sewing again. The machine will stop automatically when changing of thread color is required. Raise the presser foot lifter. Trim the needle thread.
- ④ Presser foot lifter
 - ⑦ Needle thread

* Trim the jump threads. Change the thread, hook the thread to the thread holder and start sewing the next section.

Design with jump threads



Jump thread

- 5 The embroidery pattern is sewn against the centerlines.
- ⑧ Centerlines

* When the bobbin thread runs out, stop the machine, remove the embroidery hoop (Refer to page 20) and insert a full wound bobbin (Refer to pages 9-11). Press the stitch back button to move to re-position 5-10 stitches back before the bobbin thread ran out and start sewing again (Refer to pages 8).

- ⑨ Stitch back button

Resume Function

The last pattern sewn before turning the power switch off will resume when you turn the power switch on again. You can continue sewing from the last sewn point.

- 1 Turn the power switch on to initialize the machine (Refer to page 7).

① Power switch

- 2 Connect your device to the embroidery machine (Refer to pages 21-25).

Launch the app “dot Customizer”.

② “dot Customizer”

- 3 Tap “Press to connect” to connect with the machine.

③ “Press to connect”

- 4 Tap “?” icon.

④ “?” icon

- 5 Tap “Recover”.

- 6 Press the trace button to move the embroidery hoop to the original position.

⑤ Trace button

- 7 Press the stitch back button to move to the position back 5-10 stitches, and resume the pattern (Refer to pages 8).

⑥ Stitch back button

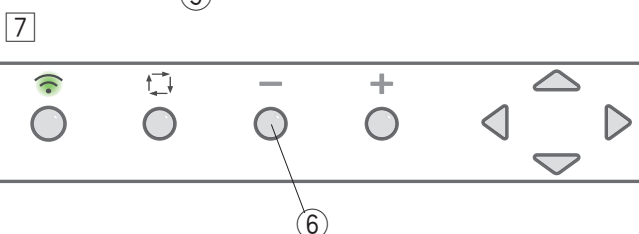
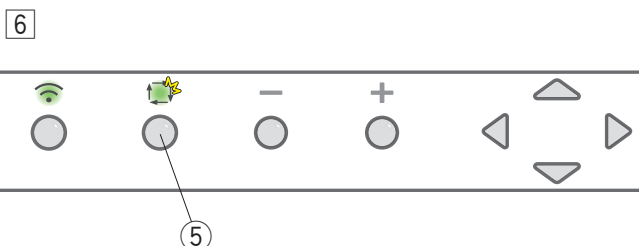
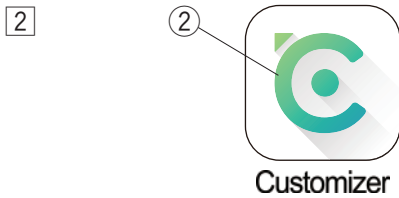
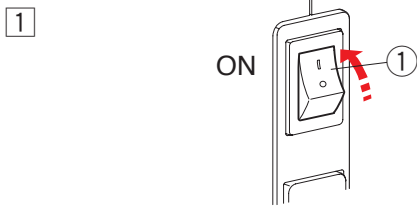

Applique

Prepare the applique fabric, background fabric, stabilizer and glue.

Example: Duck Applique

Send the design Applique>AP-01 to the machine (Refer to page 26).

Thread the machine and draw up the bobbin thread.

For inserting the bobbin, refer to page 11.

For threading the machine, refer to pages 12-14.

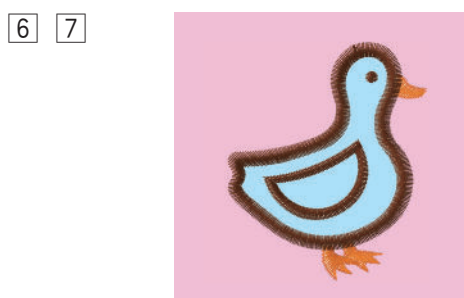
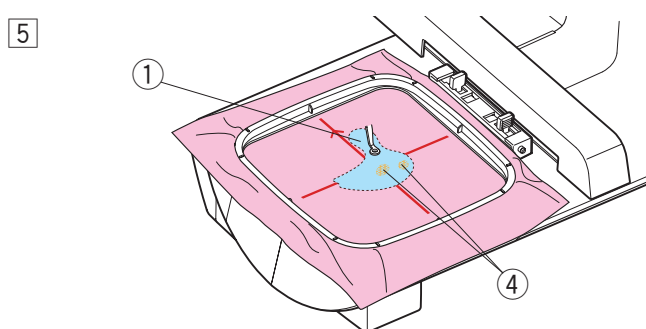
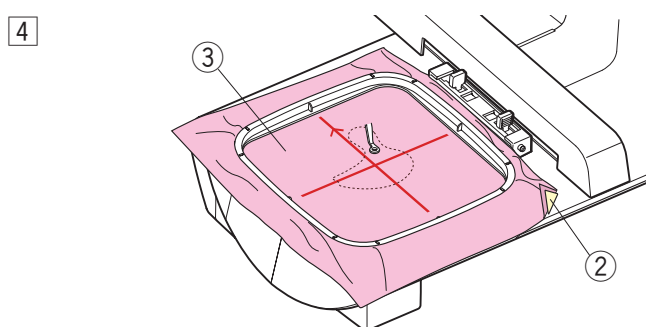
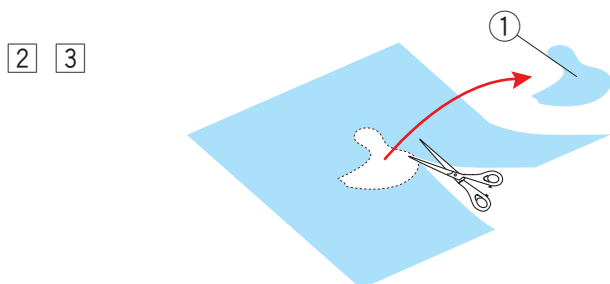
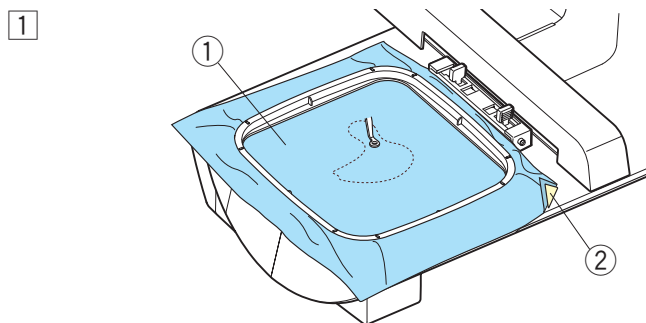

- 1 Attach the stabilizer to the applique fabric and set the applique fabric in the embroidery hoop. Attach the embroidery hoop to the carriage and sew the first color section.
 - 1 Applique fabric
 - 2 Stabilizer

- 2 After finishing the first color section, remove the embroidery hoop from the carriage.

- 3 Remove the applique fabric and cut the design along the seam line.
 - 1 Applique fabric

- 4 Attach the stabilizer to the background fabric and set the background fabric in the embroidery hoop. Attach the embroidery hoop to the carriage and sew the second color section.
 - 2 Stabilizer
 - 3 Background fabric

You can sew the second color section with the first color thread.

- 5 Attach the applique with glue (cut as in step 3) along the seam line on the background fabric lightly.
 - 1 Applique fabric
 - 4 Glue

WARNING:

Apply the glue lightly where the machine will not stitch.

If the glue sticks to the needle or the hook race, it may cause breakage or malfunction.

- 6 Start the machine to sew from the third color section onward.

- 7 Sewing result.

Cutwork

Prepare the fabric and stabilizer.

Example: Flower cutwork

Send the design Cutwork>CU-01 to the machine (Refer to page 26).

Thread the machine and draw up the bobbin thread.

For inserting the bobbin, refer to page 11.

For threading the machine, refer to pages 12-14.

1 Attach the stabilizer to the fabric and set the fabric in the embroidery hoop.

- ① Fabric
- ② Stabilizer

2 Attach the embroidery hoop to the carriage and sew.

3 Remove the embroidery hoop from the carriage. Remove the fabric from the embroidery hoop. Cut the areas inside the design along the seam line of a dark color. Fold the fabric for easier cutting.

4 Sewing result.

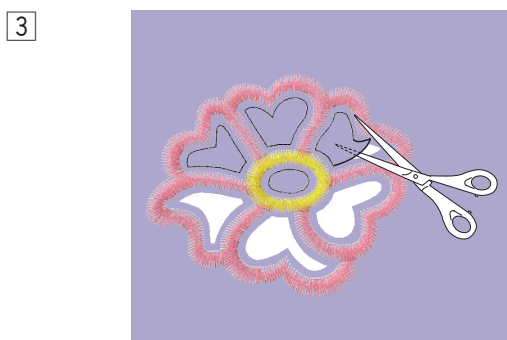
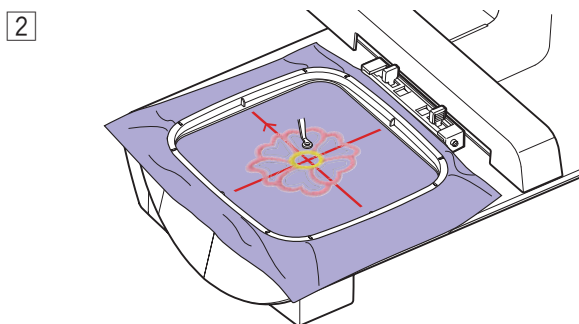
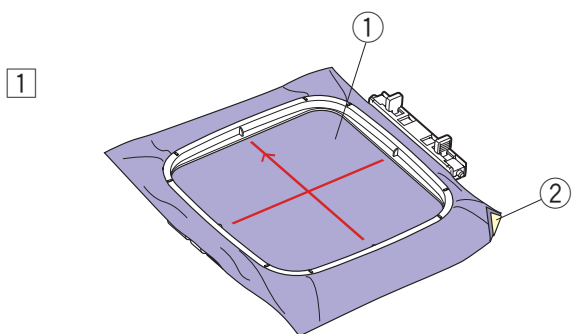

CARE AND MAINTENANCE

Replacing Needles

⚠ WARNING:

Always make sure to turn the power switch off and disconnect the machine from the wall outlet before changing the needle. Otherwise, it may cause breakage or malfunction.

- 1 Turn the power switch off and unplug the machine. Lower the presser foot lifter. Turn the handwheel toward you to raise the mark at its highest position.
 - ① Power switch
 - ② Power supply plug
 - ③ Wall outlet
 - ④ Presser foot lifter
 - ⑤ Mark
- 2 Loosen the needle clamp screw by turning it counterclockwise with the screwdriver and remove the needle.
 - ⑥ Needle clamp screw
 - ⑦ Screwdriver
- 3 Insert a new needle into the needle clamp with the flat side of the needle to the rear. When inserting the needle into the needle clamp, push it up as far as it will go. Tighten the needle clamp screw firmly with the screwdriver.
 - ⑦ Screwdriver
 - ⑧ Flat side

⚠ WARNING:

A loose needle or a loose screw may cause machine malfunction or needle to break.

Checking the needle

To check needle straightness, place the flat side of the needle onto something flat (a needle plate, glass etc.).

The gap between the needle and the flat surface should be consistent.

Never use a bent or blunt needle.

- ⑨ Gap

⚠ WARNING:

Use size 11 blue tipped needle for fine fabrics. Organ needle HA X 1, HA X 1SP #11 are also recommended.

Using a wrong needle may cause malfunction or needle to break.

- ORGAN NEEDLES is a trademark and brand of Organ Needle Co., Ltd

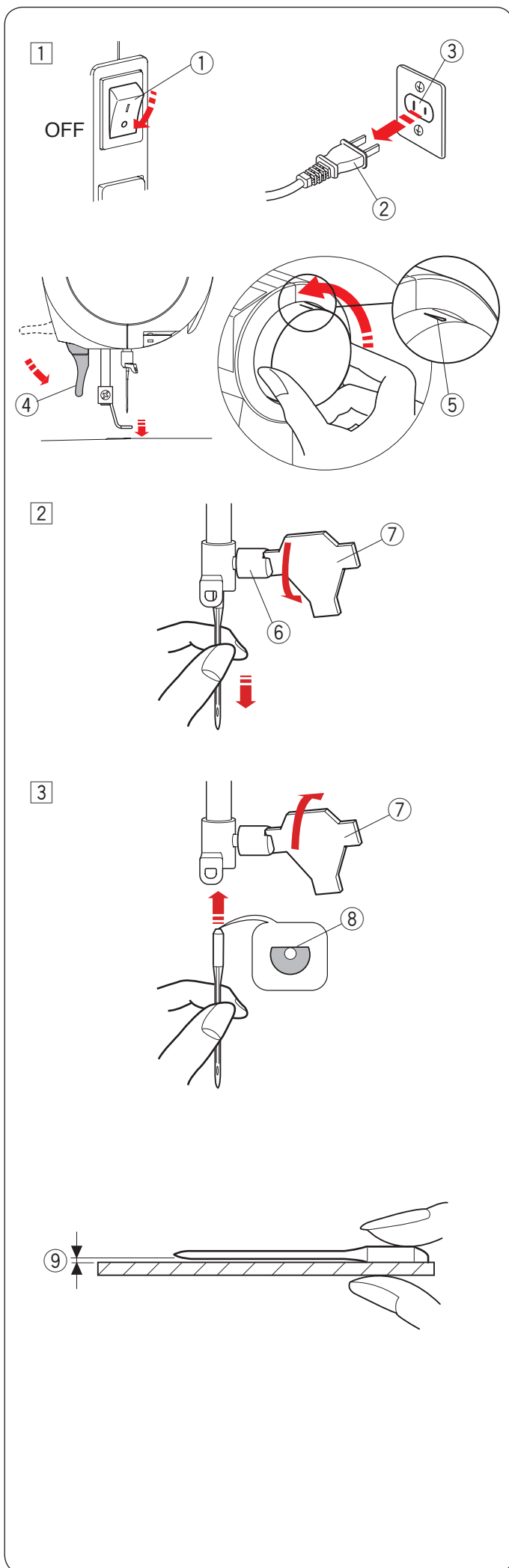

Replacing Needles while Embroidering

Move the embroidery hoop to the right corner when replacing a needle while embroidering.

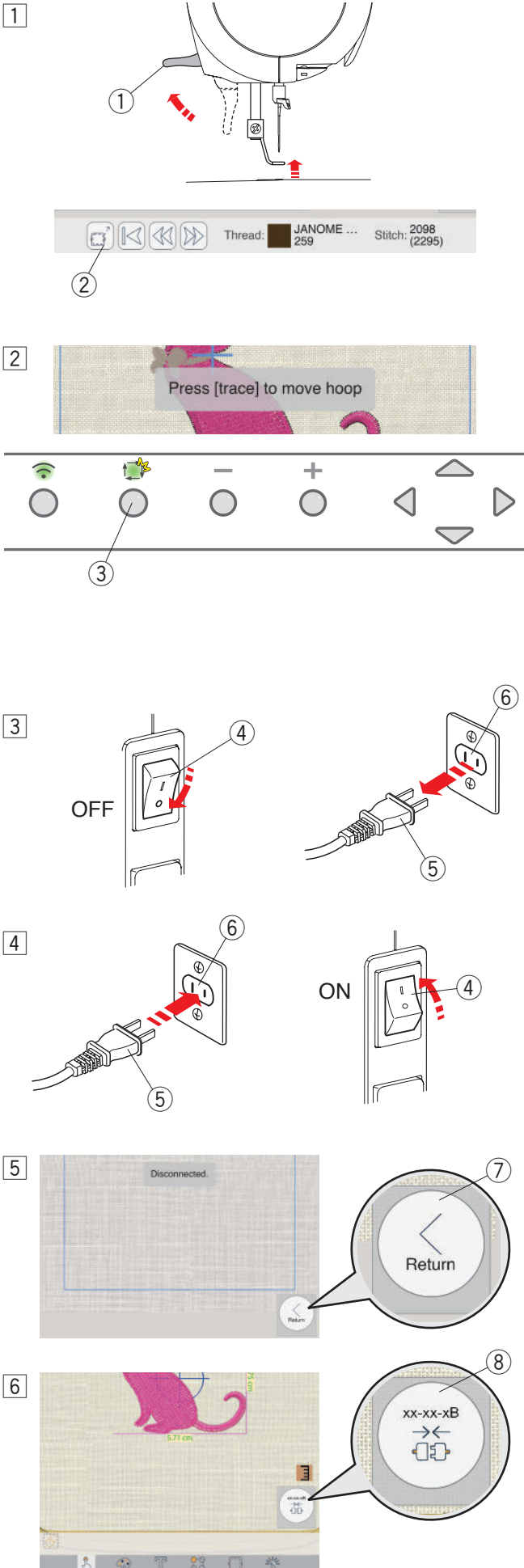

- 1 Raise the presser foot lifter.
Tap the hoop retract icon on the confirmation screen.

- ① Presser foot lifter
- ② Hoop retract icon

- 2 Press the trace button to move the embroidery hoop to the right corner.

- ③ Trace button

⚠ WARNING:

Always make sure to turn the power switch off and disconnect the machine from the wall outlet before changing the needle. Otherwise, it may cause breakage or malfunction.

- 3 Turn the power switch off and unplug the machine. Change the needle (Refer to page 32).

- ④ Power switch
- ⑤ Power supply plug
- ⑥ Wall outlet

- 4 Insert the power supply plug into the wall outlet and turn the power switch on (Refer to page 7).

- ④ Power switch
- ⑤ Power supply plug
- ⑥ Wall outlet

- 5 Connect your smart device to the embroidery machine (Refer to pages 21-25).

- Tap the return icon.
- ⑦ Return icon

* The message "Searching for machines..." appears on the lower right corner of the screen when the smart device failed to connect. Connect your smart device with the embroidery machine by wireless LAN again.

- 6 Tap "Connect" icon to connect the application with the machine.

- ⑧ "Connect" icon

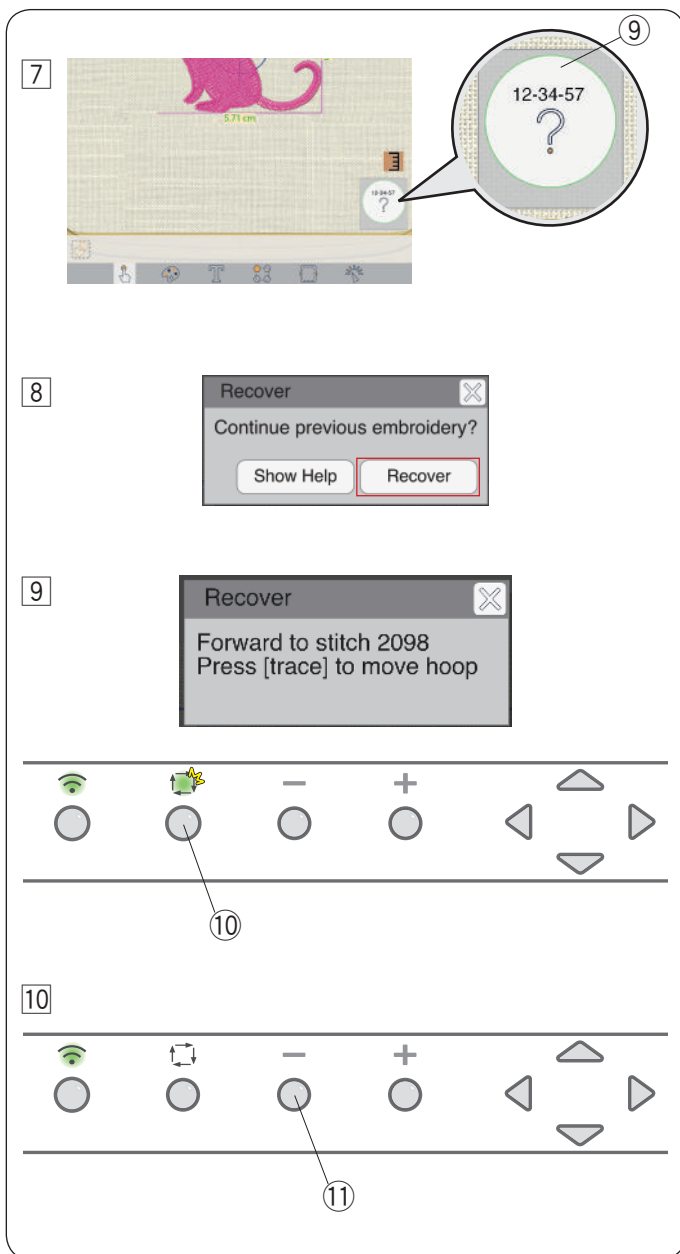

7 Tap “?” icon.

9 “?” icon

8 Tap "Recover".

9 Press the trace button on the machine to return the embroidery hoop to the original position.

10 Trace button

10 Press the stitch back button to move the position 5 - 10 stitches before, and start sewing again (Refer to pages 8).

11 Stitch back button

Thread and Needle Chart

Fabric	Needle thread (Upper thread)	Bobbin thread (Lower thread)	Needle
Fine fabric	Sewing machine embroidery thread	Polyester thread (#90-100 (59-53D/66-59dtex)) (white)	Blue tip needle or Size 75/11 **See below recommendation
Medium Knit	<ul style="list-style-type: none"> • JANOME Polyester • FUJIX KING STAR Polyester • Gutermann SULKY Rayon • Isacord Polyester • MADEIRA Rayon • Mettler Polysheen • Robison-Anton Polyester • Robison-Anton Rayon • Wonderfil Splendor Rayon 		

* Do not use an embroidery thread for the bobbin thread.

** You can also use organ needle HA x 1 #11, HA x 1SP #11.

Cleaning the Hook Area

Clean the hook area regularly.

⚠ WARNING:

Always make sure to turn the power switch off and disconnect the machine from the power supply before cleaning the hook area.

Otherwise, it may cause breakage or malfunction. Do not dismantle the machine in any way other than as explained in this section.

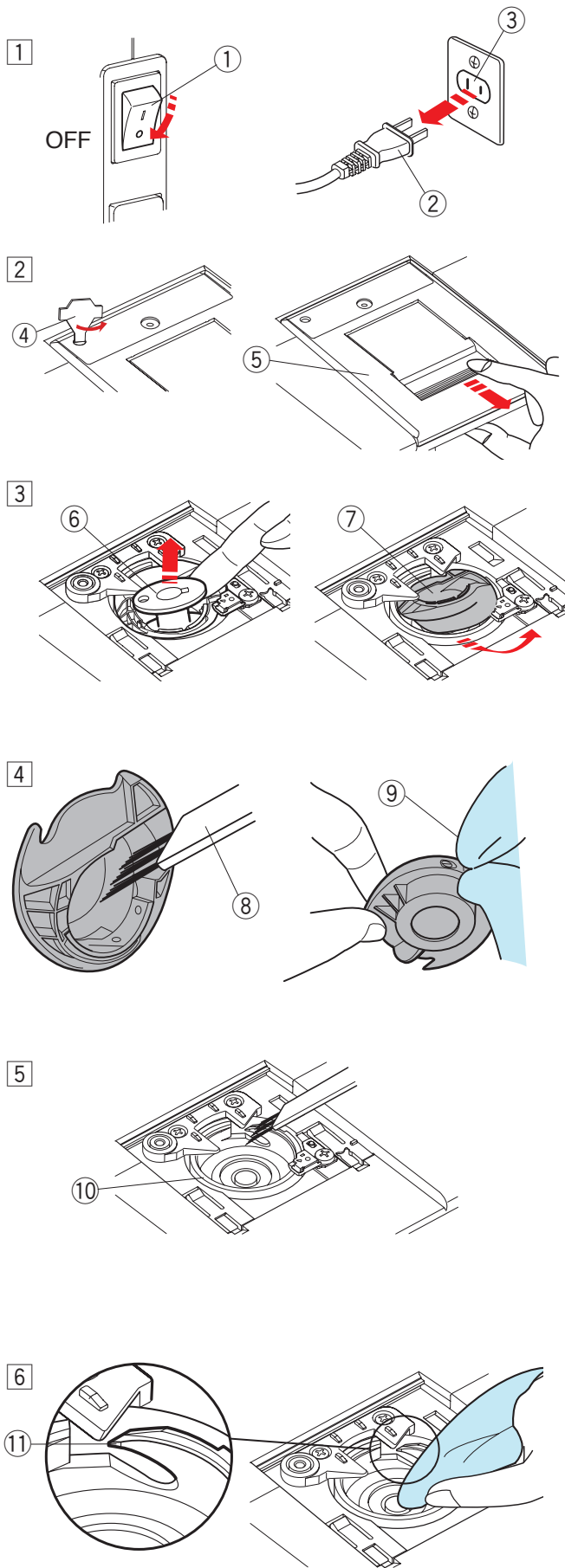

- 1 Turn the power switch off and unplug the machine. Remove the needle (Refer to page 32).

- ① Power switch
- ② Power supply plug
- ③ Wall outlet

- 2 Remove screw on the needle plate with the screwdriver. Slide the needle plate toward you to remove it.

- ④ Screwdriver
- ⑤ Needle plate

- 3 Take out the Bobbin. Take out the bobbin holder.

- ⑥ Bobbin
- ⑦ Bobbin holder

- 4 Clean the bobbin holder with the lint brush. Wipe the bobbin holder thoroughly both inside and outside with a soft cloth.

- ⑧ Lint brush
- ⑨ Soft cloth

- 5 Clean the hook race with the lint brush.

- ⑩ Hook race

- 6 Clean the inside and tip of the hook race with a soft cloth.

⚠ WARNING:

Do not touch the tip of the hook as it is very sharp. Contact may cause breakage or malfunction.

- ⑪ Tip of the hook

7

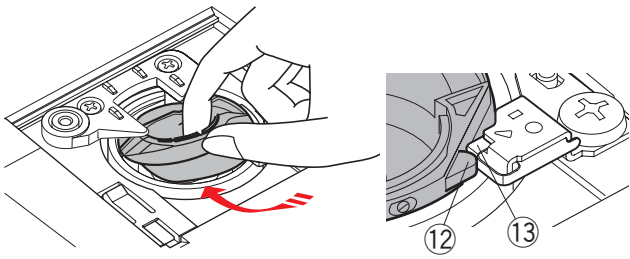

7 Insert the bobbin holder so that the knob fits next to the stopper in the hook race.

Turn the handwheel towards you for 1 full rotation to check if the bobbin holder is correctly inserted.

- ⑫ Knob
- ⑬ Stopper

Attach the needle plate and the needle.

⚠ WARNING:

- Make sure that the bobbin holder is correctly inserted.
- Make sure that the setscrew on the needle plate is firmly tightened.

NOTE:

This machine does not require oiling.

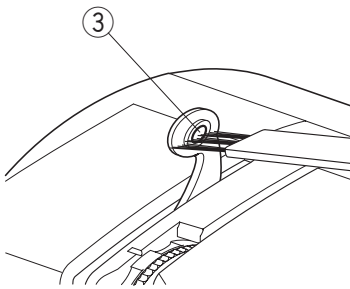
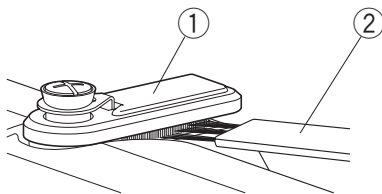

Cleaning the Thread Path

Clean lint and wax in the tension area with the lint brush. Clean under the thread guide with the lint brush.

- ① Thread guide
- ② Lint brush

Clean the eye of the take-up lever with lint brush.

Use the tail of brush to scrape the dust off from the take-up lever if the dust is stick on it.

- ③ Eye of take-up lever

⚠ WARNING:

Do not use a metal brush to clean the eye of the take-up lever to prevent damages.

TROUBLESHOOTING

How to Remove Tangled Thread under the Hoop

⚠ WARNING:

Do not turn the handwheel forcibly if the embroidery becomes tangled. Otherwise, it may cause breakage or malfunction.

- 1 Turn the power switch off.
Raise the presser foot lifter.
 - ① Power switch
 - ② Presser foot lifter

- 2 Hold the edge of the hoop and raise it lightly to make space between the hoop and the embroidery machine. Insert scissors in the space and cut the tangled thread.

⚠ WARNING:

Be careful not scratch the needle plate or the machine with scissors when cutting the tangled thread. It may cause breakage or malfunction.

- 3 Turn the handwheel to raise the needle and remove the embroidery hoop from the carriage.

⚠ WARNING:

Do not turn the handwheel forcibly if the embroidery becomes tangled. Contact the store from which the machine was purchased.

- 4 Remove the needle plate and clean the hook area (Refer to pages 35-36).

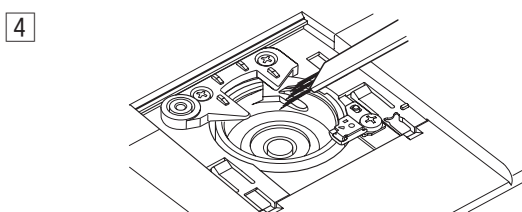
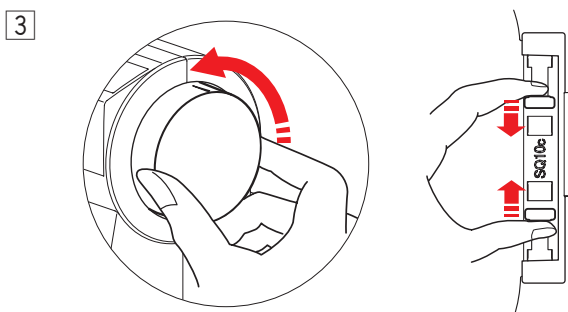
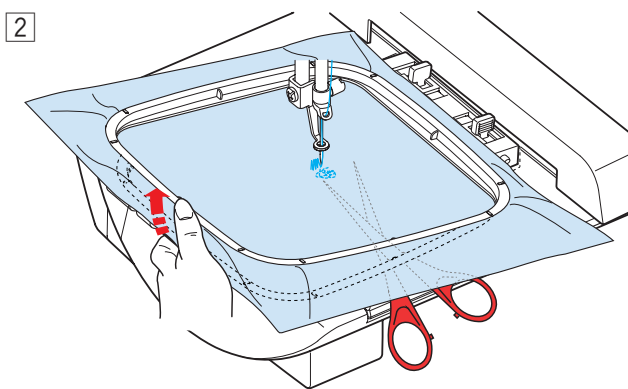
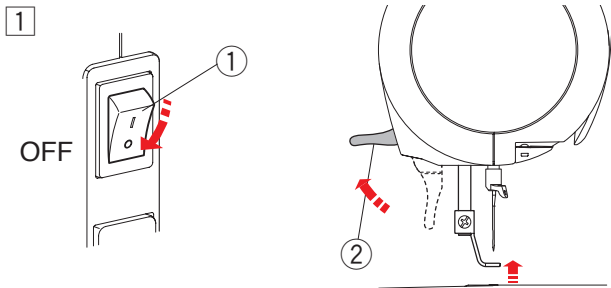



Troubleshooting

Please also refer to the FAQ on the online.

	Condition	Cause	Remedy	Reference
1	The machine does not run.	<ol style="list-style-type: none"> The machine is not plugged in. The embroidery design is not transferred. The thread is tangled in the take-up lever. The thread is tangled in the hook area. 	<p>Insert the power supply plug correctly.</p> <p>Transfer the embroidery design to the machine.</p> <p>Remove the tangled thread.</p> <p>Remove the tangled thread and clean the hook area.</p>	<p>Page 6</p> <p>Page 26</p> <p>–</p> <p>Pages 35-37</p>
2	The machine is noisy.	<ol style="list-style-type: none"> The thread is tangled in the hook area. The fabric is caught in the machine. A faint humming sound is heard from the internal motors. 	<p>Remove the tangled thread.</p> <p>Remove the fabric.</p> <p>Not abnormal</p>	<p>Pages 35-37</p> <p>–</p> <p>–</p>
3	A noise occurs when initializing.	<ol style="list-style-type: none"> An object is caught between the carriage and machine body. 	<p>Remove the object.</p>	<p>–</p>
4	Function buttons do not work.	<ol style="list-style-type: none"> The embroidery machine condition or the state is not appropriate. The bobbin winder spindle is in the winding position. (Only the start/stop button works.) The circuit board is defective. 	<p>Check the button lights condition</p> <p>Move the bobbin winder spindle to the left.</p> <p>Contact the service center or the store from whom the machine was purchased.</p>	<p>Page 41</p> <p>Page 7</p> <p>–</p>
5	The handwheel is not turned.	<ol style="list-style-type: none"> The presser foot lifter is raised to the extra lifted position. The thread is tangled in the hook area. The fabric is too thick or too hard. 	<p>Lower the presser foot lifter.</p> <p>Remove the tangled thread.</p> <p>Use appropriate fabric.</p>	<p>Page 6</p> <p>Page 37</p> <p>–</p>
6	The wireless LAN button is not turned on when connecting the machine in the client mode.	<ol style="list-style-type: none"> The wireless LAN router is not switched on. Failed to switch to client mode. 	<p>Switch the wireless LAN router on.</p> <p>Restart client mode setting.</p>	<p>–</p> <p>Page 24</p>
7	The smart device and the embroidery machine cannot be connected.	<ol style="list-style-type: none"> The mode does not match. 	<p>Check the mode. Switch the mode to client or access mode if necessary.</p>	<p>Pages 21-25</p>
8	The embroidery design is not transferred.	<ol style="list-style-type: none"> The machine is not initialized. The bobbin winder spindle is in the winding position. 	<p>Initialize the machine.</p> <p>Move the bobbin winder spindle to the left.</p>	<p>Page 7</p> <p>Page 7</p>
9	A noise occurs when the needle pierces the fabric.	<ol style="list-style-type: none"> The fabric is too thick or too hard. The size of the embroidery design is reduced less than 80%. Overlapped stitching. 	<p>Use appropriate fabric.</p> <p>Reduce the size of the embroidery design not less than 80%.</p> <p>Test sew on a scrap piece of fabric.</p>	<p>Page 16</p> <p>–</p> <p>Page 16</p>

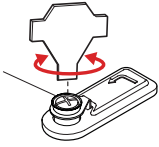
Troubleshooting

	Condition	Cause	Remedy	Reference
10	The bobbin is not wound correctly.	<ol style="list-style-type: none"> 1. Thread path is incorrect. 2. The bobbin is not wound evenly. 	<p>Use the proper thread path. Turn the adjusting screw.</p> <p>NOTE: Do not turn the adjusting screw too much. Otherwise, a part may drop off.</p>  <p>Thread is wound onto the upper side of bobbin. Thread is wound onto the lower side of bobbin.</p>   <p>Turn the adjusting screw clockwise. Turn the adjusting screw counterclockwise.</p>	Page 10 –
11	The needle thread breaks.	<ol style="list-style-type: none"> 1. The needle thread is tangled in the spool pin. 2. The needle thread is not threaded correctly. 3. The needle thread tension is too tight. 4. The needle thread is tangled in the hook area. 5. The needle is bent or blunt. 6. The needle is not inserted correctly. 7. The loose end of the needle thread is not hooked to the thread holder when starting to sew. 8. A proper needle or thread is not used. 	<p>Press the spool holder firmly against the spool of thread. Thread the machine correctly. Adjust the thread tension. Clean the hook area.</p> <p>Change the needle. Insert the needle properly. Slide the loose end of the needle thread into the thread holder when starting to sew. Use appropriate needle and thread.</p>	Page 9 Pages 12-13 Page 15 Pages 35-36 Page 32 Page 32 Page 28 Page 34
12	The bobbin thread breaks.	<ol style="list-style-type: none"> 1. The bobbin is no inserted in the machine correctly. 2. The thread is tangled in the hook area. 3. The bobbin is damaged and does not turn smoothly. 4. An appropriate thread is not used. 	<p>Insert the bobbin in the machine correctly. Clean the hook area. Change the bobbin.</p> <p>Use appropriate thread.</p>	Page 11 Pages 35-36 – Page 34
13	The needle breaks.	<ol style="list-style-type: none"> 1. The needle is not inserted properly. 2. The needle is bent or blunt. 3. The needle clamp screw is loose. 4. An appropriate needle is not used. 	<p>Insert the needle correctly. Change the needle. Change the needle and tighten the needle clamp screw firmly. Use appropriate needle.</p>	Page 32 Page 32 Page 32 Page 34
14	Difficult to replace the needle.	<ol style="list-style-type: none"> 1. The carriage is not moved away. 	Tap "Hoop retract" icon and move the carriage.	Page 33
15	Skipped stitches	<ol style="list-style-type: none"> 1. The needle is not inserted properly. 2. The needle is bent or blunt. 3. The needle thread is not threaded properly. 4. The needle is defective (rusted, burr on needle eye or tip). 5. Appropriate needle or thread is not used. 6. The embroidery hoop is not set properly. 7. The fabric is pulled or caught while embroidering. 8. The fabric is not set in the embroidery hoop tightly. 	<p>Insert the needle correctly. Change the needle. Thread the machine correctly. Change the needle.</p> <p>Use appropriate needle and thread. Re-set the embroidery hoop. Re-set fabric to hoop.</p> <p>Set the fabric in the embroidery hoop tightly.</p>	Page 32 Page 32 Pages 12-13 Page 32 Page 34 Page 19 Pages 18-19 Page 18



Troubleshooting







	Condition	Cause	Remedy	Reference
16	Patterns are distorted.	<ol style="list-style-type: none"> The bobbin thread is not thread correctly. The bobbin is not inserted in the bobbin holder correctly. The bobbin thread is not inserted between the guide and the tension leaf (black blade). The needle thread tension is too tight. The size of the design is enlarged more than 120% or reduced less than 80%. The fabric is not set in the embroidery hoop tightly. The hoop tightening screw is loose. The carriage interferes with something around the machine. The fabric is pulled or caught while embroidering. The fabric is too heavy. The fabric puckers. 	<p>Remove bobbin and insert correctly.</p> <p>Adjust the thread tension. Change the size of the design between 80 - 120%. Set the fabric in the embroidery hoop tightly. Tighten the hoop tightening screw firmly. Do not place anything around the machine. Set the fabric in the embroidery hoop correctly. Support the fabric so as not to interfere with carriage movement. Use a stabilizer.</p>	<p>Page 11</p> <p>Page 15 –</p> <p>Page 18</p> <p>Page 18</p> <p>–</p> <p>Pages 18-19</p> <p>–</p> <p>Page 16</p>
17	Thread tension is unstable.	<ol style="list-style-type: none"> Lint has collected on the thread guide or take-up lever. Appropriate thread is not used. 	<p>Remove dust and lint.</p> <p>Use appropriate thread.</p>	<p>Page 36</p> <p>Page 34</p>
18	The bobbin thread appears on the right side of the fabric.	<ol style="list-style-type: none"> The needle thread tension is too tight. The bobbin thread is not threaded correctly. The bobbin is inserted upside down. 	<p>Adjust the needle thread tension.</p> <p>Rethread the bobbin thread.</p> <p>Insert the bobbin in the machine correctly.</p>	<p>Page 15</p> <p>Page 11</p> <p>Page 11</p>
19	<p>Beginning of embroidery:</p> <ul style="list-style-type: none"> "Thread break" appears. The needle thread appears on the wrong side of the fabric. The needle thread forms loop on the right side of the fabric. Abnormal noise comes from hook area. 	<ol style="list-style-type: none"> The presser foot lifter is lowered when threading the machine. 	<p>Raise the presser foot lifter and rethread the machine.</p>	<p>Pages 12-13</p>
20	<p>Beginning of embroidery:</p> <p>Thread is getting tangled on the wrong side of the fabric.</p>	<ol style="list-style-type: none"> Thread is being pulled into the wrong side of the fabric. The needle thread is not threaded properly. 	<p>Hook the needle thread to the thread holder and start to sew 5 to 6 stitches.</p> <p>Thread the machine correctly.</p>	<p>Page 28</p> <p>Pages 12-13</p>

* It is not abnormal for a faint humming sound to be heard from the internal motors.

* The button area may become warm after several hours of continuous use.

Operation Button Light

Normal		Status	Operation
	ON	Ready to start the machine	Press the start/stop button.
	Blinking slowly	Paused	Press the start/stop button.
	Blinking rapidly	Ready to change the thread	Raise the presser foot lifter. Change the thread. Lower the presser foot lifter. Press the start/stop button.
	ON	Bobbin winding mode	Press the start/stop button to wind the bobbin.
	Blinking slowly	Ready to initialize the machine	Press the start/stop button.
		Ready to move the carriage position	Press the start/stop button to move the hoop to the correct position.
	ON	Sewing	

Error		Status	Operation
 	Blinking rapidly	Motor error	Turn the power switch off. Remove the tangled threads on the take-up lever or hook area. Turn the power switch on. If the problem persists, contact the store from whom the machine was purchased.
 	Blinking rapidly	Communication error	Turn the power switch off and on. If the problem persists, contact the store from whom the machine was purchased.
	Blinking slowly	Wrong presser foot position	Move the presser foot to the correct position.
		Needle is lowered.	Turn the handwheel toward you to raise the mark at its highest position.
		Bobbin winding spindle is not returned.	Push the bobbin winder spindle to the left and initialize the machine.
	Blinking rapidly	Needle thread breakage	Raise the presser foot lifter and re-thread the machine. Lower the presser foot lifter and start sewing.
		Motor overload	Turn the power switch off. Check if the fabric is too thick, folded, overlapped, or the needle is bent. Turn the power switch on.

